

VTXB

VT6B

VT6C

VT6CSH

VT6D

VT6E

VT6CM

VT6GC

VT6CP

VT6DM

VT6EM

VT7B

VT7QC

VT7D

VT7E

SINGLE VANE PUMPS



VTXB 1 - B09 - 1 R 00 - D 1 02 *

Series

Mounting

- 1 - SAE A
- 2 - SAE B

Cam ring

Volumetric displacement cm^3 / rev (in^3 / rev)

- B02 = 5.8 (0.35)
- B03 = 9.8 (0.59)
- B04 = 12.8 (0.78)
- B05 = 15.9 (0.97)
- B06 = 19.8 (1.21)
- B07 = 22.5 (1.37)
- B08 = 24.9 (1.52)
- B09 = 28.0 (1.71)
- B10 = 31.8 (1.94)
- B11 = 34.9 (2.13)
- B12 = 41.0 (2.50)(cont. 175 bar, Max. int 210 bar)
- B14 = 45.0 (2.75)(cont. 140 bar, Max. int 175 bar)

Type of Shaft

TXB1

- 1 - Keyed (Non SAE)
- 2 - Keyed
- 3 - Splined
- 4 - Splined
- 5 - Keyed
- V - Splined

TXB2

- 1 - Keyed (Non SAE)
- 2 - Keyed
- 4 - Splined

Direction of rotation (view on shaft end)

- R - clockwise
- L - counter-clockwise

Modifications

Port connections

CODE	S	P
00	SAE 20 1" 5/8 12 UNF-2B	SAE 12 1" 1/16 12 UNF-2B
01	1" 1/4 SAE 4 bolt (UNC)	3/4" SAE 4 bolt (UNC)
M0	1" 1/4 SAE 4 bolt (METRIC)	3/4" SAE 4 bolt (METRIC)
02	1" 1/4 BSP	3/4" BSP
03	1" 1/4 NPTF	SAE 12 1" 1/16 12 UNF-2B
0X	1" 1/4 NPTF	3/4" NPTF
MX	Ø28 SAE 4 bolt (METRIC)	Ø15 SAE 4 bolt (METRIC)

Seal class

- 1 - S1 (for mineral oil)
- 4 - S4 (for fire resistant fluids)
- 5 - S5 (for mineral oil and fire resistant fluids)

Design letter

Porting combination

00 - standard

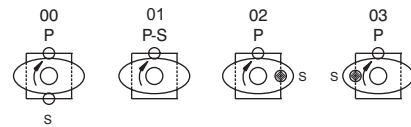

S - Suction port P - Pressure port

OPERATING CHARACTERISTICS (24 cSt)

Pressure port	Series	Volumetric Displacement Vp		Flow q & n = 1500 rpm						Input power p & n = 1500 rpm					
		in^3 / rev	cm^3 / rev	p = 0 bar (0 psi)		p = 140 bar (2000 psi)		p = 210 bar (3000 psi)		p = 7 bar (100 psi)		p = 140 bar (2000 psi)		p = 210 bar (3000 psi)	
				gpm	lpm	gpm	lpm	gpm	lpm	hp	kw	hp	kw	hp	kw
VTXB1 VTXB2	B02	0.35	5.8	2.30	8.7	1.4	5.9	--	--	0.53	0.4	2.81	2.1	--	--
	B03	0.59	9.8	3.88	14.7	2.9	11.9	--	--	0.67	0.5	3.62	2.7	--	--
	B04	0.78	12.8	5.08	19.2	4.33	16.4	3.97	15.0	0.93	0.7	5.23	3.9	10.06	7.5
	B05	0.97	15.9	6.31	23.8	5.55	21.0	5.18	19.6	1.00	0.75	6.64	4.9	11.2	8.3
	B06	1.21	19.8	7.85	29.7	7.12	26.9	6.66	25.2	1.07	0.8	8.05	6.0	12.34	9.2
	B07	1.37	22.5	8.92	33.7	8.17	30.9	7.80	29.5	1.20	0.9	9.05	6.7	14.02	10.4
	B08	1.52	24.9	9.89	37.4	9.15	34.6	8.78	33.2	1.34	1.0	10.05	7.5	15.69	11.7
	B09	1.71	28.0	11.11	42.0	10.37	39.2	10.00	37.8	1.47	1.1	11.94	8.9	23.60	17.6
	B10	1.94	31.8	12.61	47.7	11.87	44.9	11.51	43.5	1.6	1.2	13.0	9.7	26.0	19.6
	B11	2.13	34.9	13.85	52.3	13.09	49.5	12.72	48.1	1.7	1.3	14.0	10.5	28.0	21.0
	B12	2.50	41.0	16.27	61.5	15.53	58.7	*	*	1.8	1.4	15.02	11.2	*	*
	B14	2.75	45.0	17.86	67.5	17.12	64.7	**	**	2.1	1.6	15.42	11.5	**	**

-- Not to use because internal leakage greater than 50% of theoretical flow.

* B12= 210 bar(3000 psi) Max.Int

** B14= 175 bar(2500 psi) Max.Int

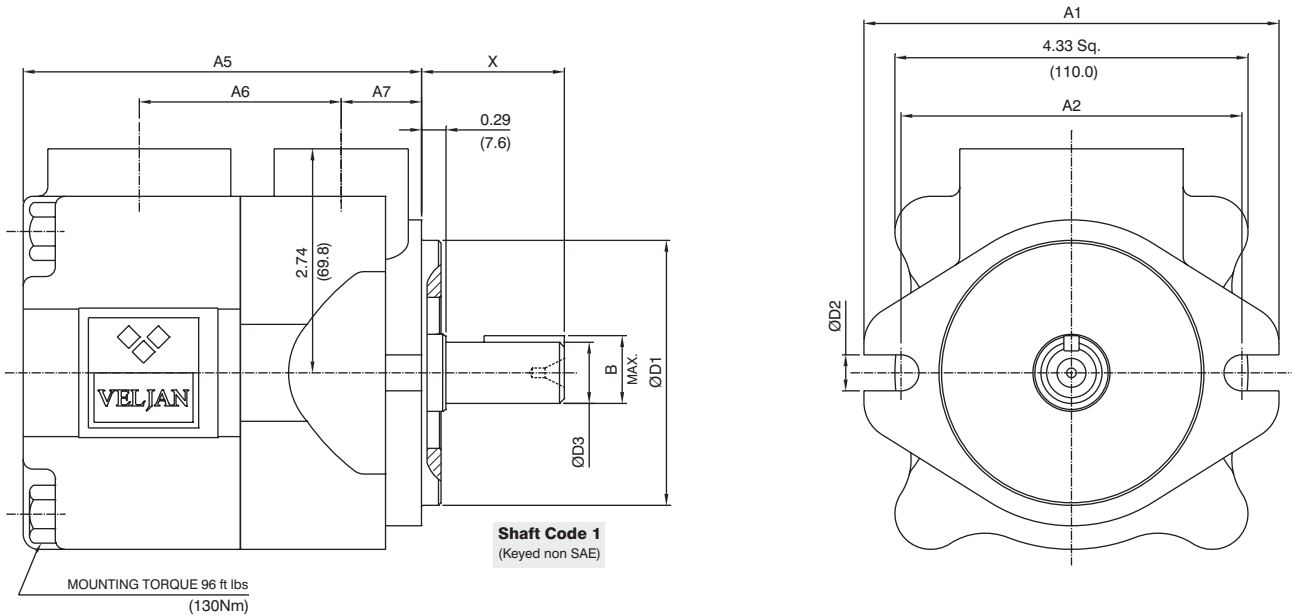
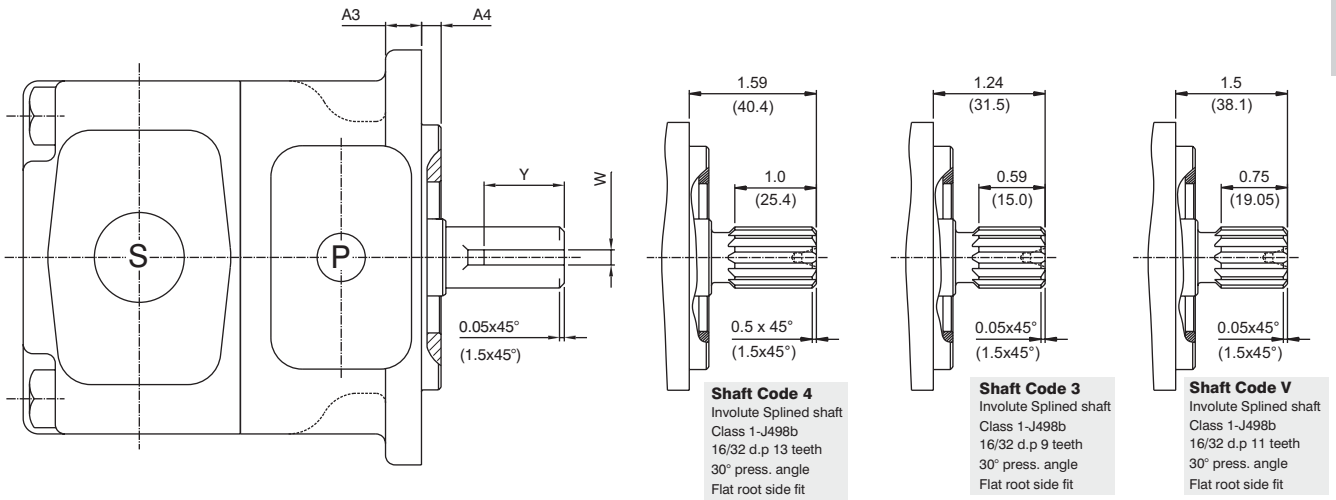

DIMENSIONS OF KEYED SHAFT in inches (mm)						
MODEL	CODE	X	Y	ØD3	B	W
TXB1	1	1.75(44.5)	0.98(25)	0.75/0.74(19.05/19.00)	0.83(21.1)	0.187/0.185(4.75/4.70)
	2	1.96(50.0)	0.98(25)	0.625/0.624(15.88/15.85)	0.69(17.7)	0.156/0.155(3.97/3.94)
	5	2.66(67.6)	1.61(41)	0.75/0.74(19.05/19.00)	0.83(21.1)	0.187/0.185(4.75/4.70)
TXB2	1	2.32(59.0)	1.25(32)	0.875/0.874(22.22/22.20)	0.96(24.5)	0.187/0.185(4.75/4.70)
	2	2.81(71.4)	1.49(38)	0.875/0.874(22.22/22.20)	0.96(24.5)	0.250/0.248(6.35/6.30)

DIMENSIONS in inches (mm)									
MODEL	A1	A2	A3	A4	A5	A6	A7	ØD1	ØD2
TXB1	5.11(130.0)	4.18(106.2)	0.44(11.2)	0.24(6.1)	4.88(124.1)	2.47(62.9)	0.98(25.0)	3.25/3.24(82.55/82.50)	0.44(11.2)
TXB2	6.87(174.5)	5.74(146.0)	0.5(12.7)	0.38(9.7)	4.94(125.6)	2.29(58.4)	1.22(31.0)	4.00/3.99(101.60/101.55)	0.56(14.3)

SP

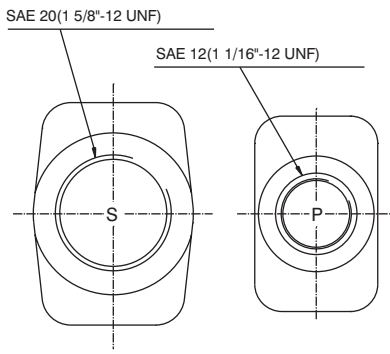

PORT CONNECTION 00

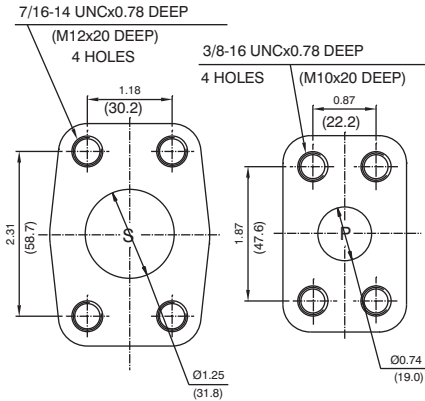

PORT CONNECTION 01&M0

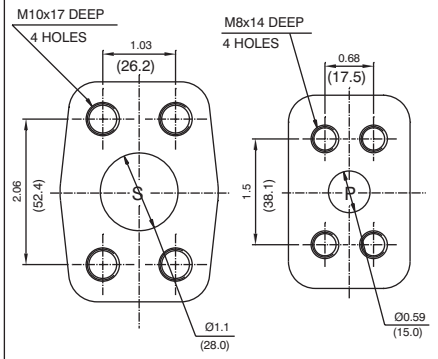

PORT CONNECTION MX

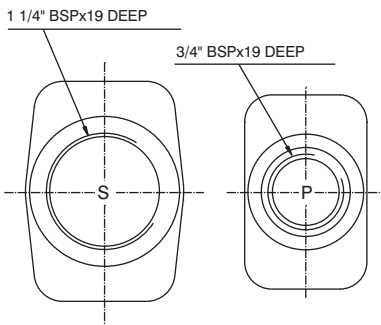

PORT CONNECTION 02

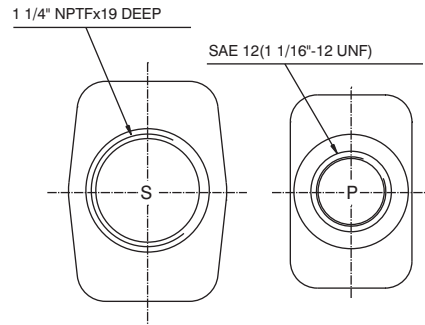

PORT CONNECTION 03

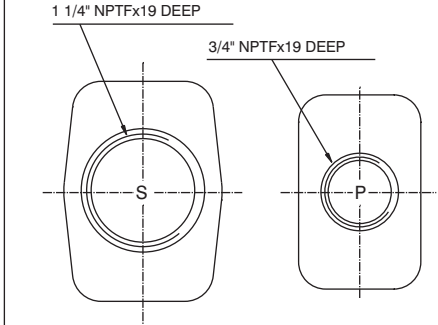

PORT CONNECTION 0X

INTERNAL LEAKAGE (TYPICAL)

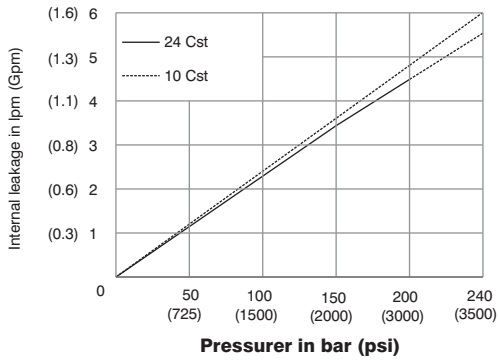

Do not operate pump for more than 5 seconds at any speed or viscosities if internal leakage is more than 50% of theoretical flow.

NOISE LEVEL (TYPICAL)

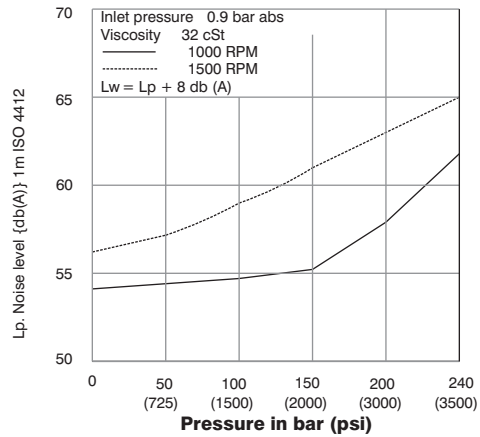

POWER LOSS HYDROMECHANIAL (TYPICAL)

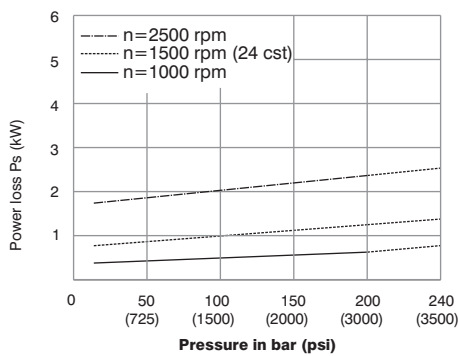

PERMISSIBLE RADIAL LOAD

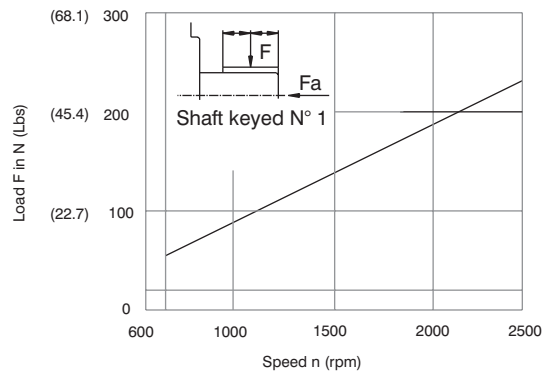

Maximum axial load permissible Fa = 500 N (113.6 lbs)

VT6B - B09 - 1 R 00 - D 1 02 *

Series

Cam ring

Volumetric displacement cm^3/rev (in^3/rev)

- B02 = 6.5 (0.39)
- B03 = 8.8 (0.54)
- B04 = 12.8 (0.78)
- B06 = 20.7 (1.26)
- B08 = 26.1 (1.59)
- B09 = 31.5 (1.92)
- B12 = 39.7 (2.42)

Type of Shaft

- 1 - Keyed (Non SAE)
- 2 - Keyed
- 3 - Splined (SAE A)
- 4 - Splined (SAE B)
- 5 - Splined SAE (11 teeth)
- 11 - Splined

Direction of rotation (view on shaft end)

- R - clockwise
- L - counter-clockwise

Porting combination

- 00 - standard

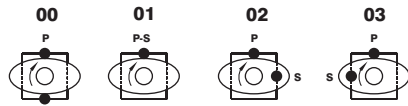

S - Suction port P - Pressure port

Modifications

Port connections

CODE	S	P
00	SAE 20 1-5/8" 12 UNF-2B	SAE 12 1-1/16" 12 UNF-2B
01	1-1/4" SAE 4 bolt (UNC)	3/4" SAE 4 bolt (UNC)
M0	1-1/4" SAE 4 bolt (METRIC)	3/4" SAE 4 bolt (METRIC)
02	1-1/4" BSP	3/4" BSP
03	1-1/4" NPTF	SAE 12 1-1/16" 12 UNF-2B
0X	1-1/4" NPTF	3/4" NPTF

Seal class

- 1 - S1 (for mineral oil)
- 4 - S4 (for fire resistant fluids)
- 5 - S5 (for mineral oil and fire resistant fluids)

Design letter

INTERNAL LEAKAGE (TYPICAL)

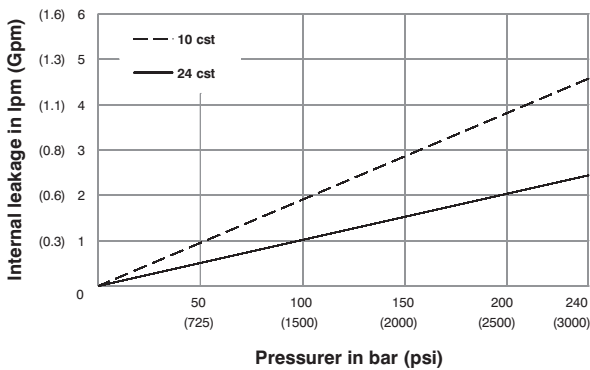

PERMISSIBLE RADIAL LOAD

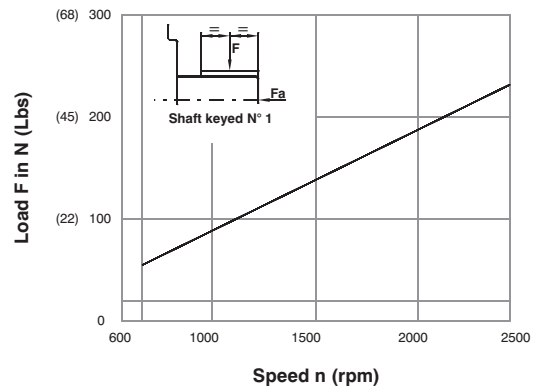

Maximum axial load permissible $F_a = 500 \text{ N}$ (113 Lbs)

OPERATING CHARACTERISTICS (24 cSt)

Pressure port	Series	Volumetric Displacement V_p		Flow q & $n = 1500 \text{ rpm}$						Input power p & $n = 1500 \text{ rpm}$					
		in^3/rev	cm^3/rev	$p = 0 \text{ bar (0 psi)}$		$p = 100 \text{ bar (1500 psi)}$		$p = 240 \text{ bar (3500 psi)}$		$p = 7 \text{ bar (100 psi)}$		$p = 100 \text{ bar (1500 psi)}$		$p = 240 \text{ bar (3500 psi)}$	
				gpm	lpm	gpm	lpm	gpm	lpm	hp	kw	hp	kw	hp	kw
VT6B	B02	0.39	6.5	2.64	10.0	2.11	8.0	-	-	0.53	0.4	2.81	2.1	-	-
	B03	0.54	8.8	3.49	13.2	2.96	11.2	2.43	9.2	0.67	0.5	3.62	2.7	7.11	5.3
	B04	0.78	12.8	5.08	19.2	4.55	17.2	4.02	15.2	0.93	0.7	5.23	3.9	10.06	7.5
	B06	1.26	20.7	8.20	31.0	7.67	29.0	7.14	27.0	1.07	0.8	8.05	6.0	12.34	9.2
	B08	1.59	26.1	10.34	39.1	9.78	37.0	9.25	35.0	1.34	1.0	10.05	7.5	15.69	11.7
	B09	1.92	31.5	12.48	47.2	11.93	45.1	11.42	43.2	1.47	1.1	11.94	8.9	23.60	17.6
B12	2.42	39.7	15.74	59.5	15.18	57.4	14.68	55.5	1.74	1.3	15.02	11.2	29.50	22.0	

-- Not to use because internal leakage greater than 50% theoretical flow.

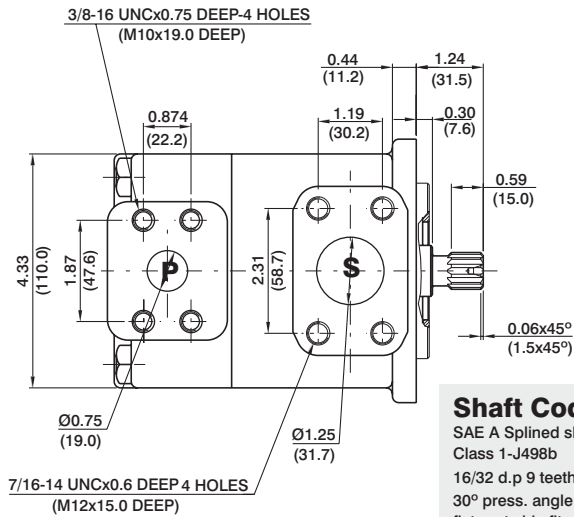

Shaft Code 3

SAE A Splined shaft
Class 1-J498b
16/32 d.p 9 teeth
30° press. angle
flat root side fit

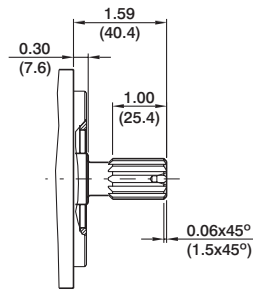

Shaft Code 4

SAE B Splined shaft
Class 1-J498b
16/32 d.p 13 teeth
30° press. angle
flat root side fit

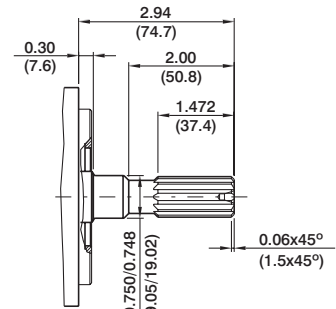

Shaft Code 11

Splined shaft
Class 1-J498b
16/32 d.p 11 teeth
30° press. angle
flat root side fit

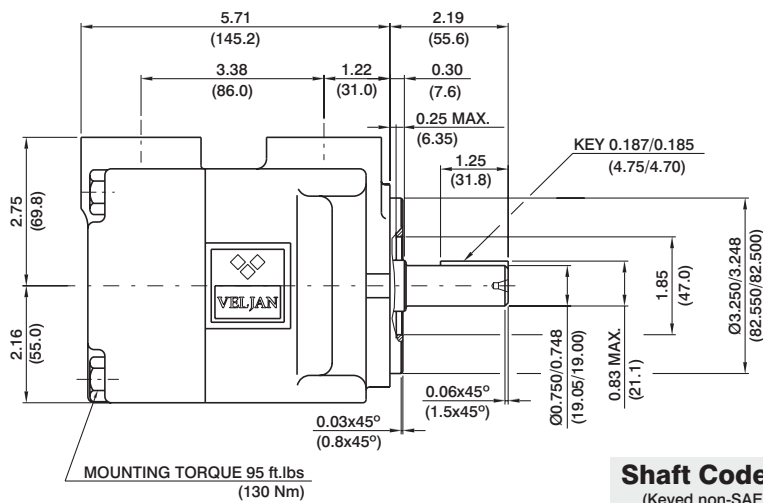

Shaft Code 1 (Keyed non-SAE)

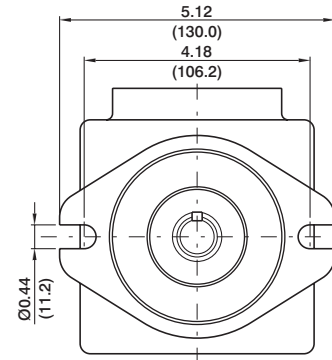

Shaft torque limits in³/revpsi(ml/revbar)

Shaft	Vp x p max.
3	5119 (5780)
4	18246 (20600)

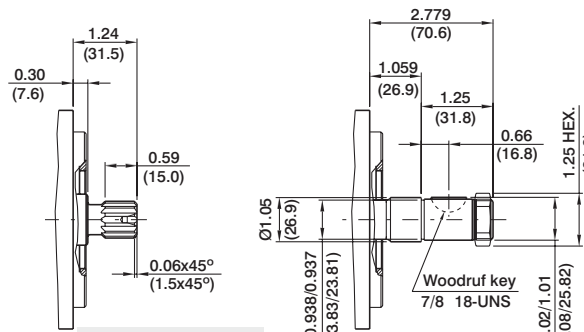

Shaft Code 5

SAE Splined shaft
Class 1-J498b
16/32 d.p 11 teeth
30° press. angle
flat root side fit

Shaft Code 2

Woodruff key
Recommended nut Torque
125 ft.lbs (170 Nm)

SAE 20(1 5/8"-12 UNF)

SAE 12(1 1/16"-12 UNF)

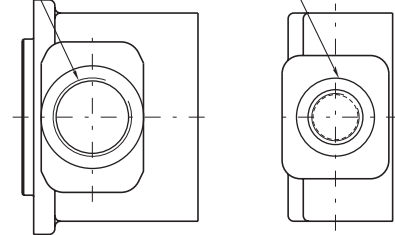

PORT CONNECTION 00

1 1/4" BSPx1.0 DEEP (25.4)

3/4" BSPx0.75 DEEP (19.0)

1 1/4" NPTFx1.0 DEEP (25.4)

SAE 12(1 1/16"-12 UNF)

1 1/4" NPTFx1.0 DEEP (25.4)

3/4" NPTFx0.75 DEEP (19.0)

PORT CONNECTION 02

PORT CONNECTION 03

PORT CONNECTION 0X



Series VT6C * - 022 - 1

Y - Metric port connection, Omit for UNC

Cam ring

Volumetric displacement cm³/rev (in³/rev)

*003/B03/Y03 = 10.8 (0.66)	015/B15/Y15 = 50.5 (3.08)
005/B05/Y05 = 17.2 (1.05)	017/B17/Y17 = 58.3 (3.56)
006/B06/Y06 = 21.3 (1.30)	020/B20/Y20 = 63.8 (3.89)
008/B08/Y08 = 26.4 (1.61)	022/B22/Y22 = 70.3 (4.29)
010/B10/Y10 = 34.1 (2.08)	025/B25/Y25 = 79.3 (4.84)
012/B12/Y12 = 37.1 (2.26)	028/B28/Y28 = 88.8 (5.42)
014/B14/Y14 = 46.0 (2.81)	031/B31/Y31 = 100.0 (6.10)

*'0' - Uni-directional 'B' - Bi-directional 'Y' - Bi-directional for cold start

Type of shaft

- 1 - keyed (SAE B)
- 2 - keyed (no SAE)
- 3 - splined (SAE B)
- 4 - splined (SAE BB)

Modifications

Seal class

- 1 - S1 (for mineral oil)
- 4 - S4 (for fire resistant fluids)
- 5 - S5 (for mineral oil and fire resistant fluids)

Design letter

Porting combination

00 - standard

00

01

02

03

S - Suction port **P** - Pressure port

Direction of rotation (view on shaft end)

- R - clockwise
- L - counter-clockwise

INTERNAL LEAKAGE (TYPICAL)

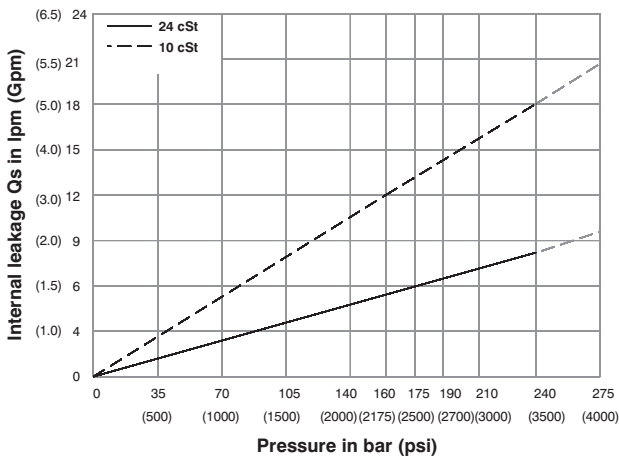

Do not operate pump more than 5 seconds at any speed or viscosity if internal leakage is more than 50% of theoretical flow.

NOISE LEVEL (TYPICAL)

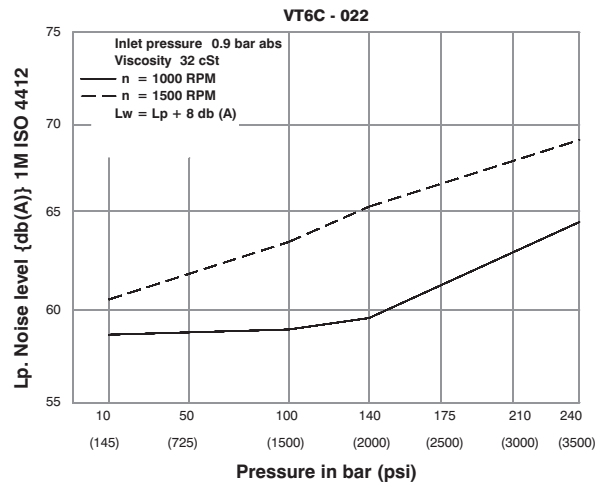

HYDROMECHANICAL POWER LOSS (TYPICAL)

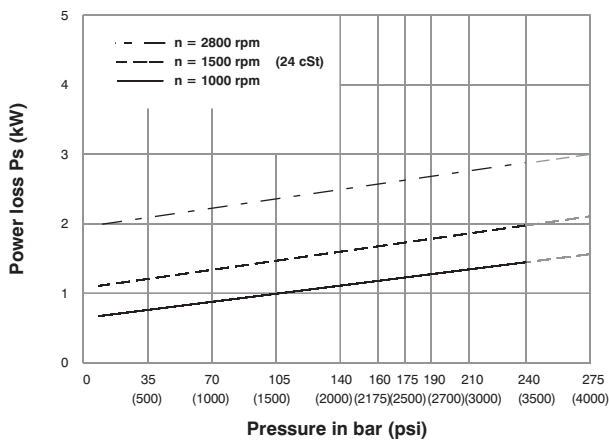

PERMISSIBLE RADIAL LOAD

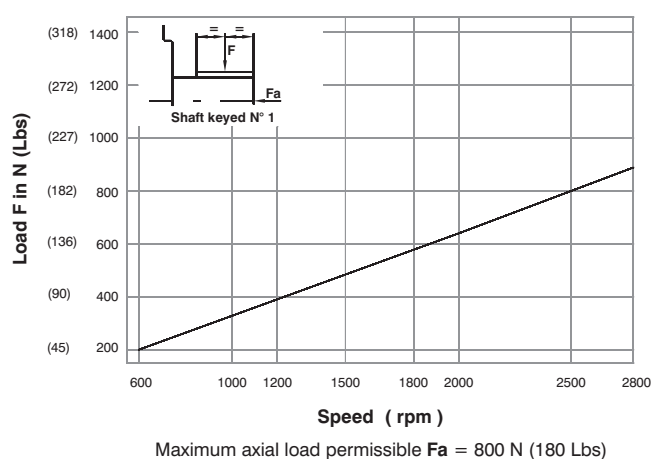

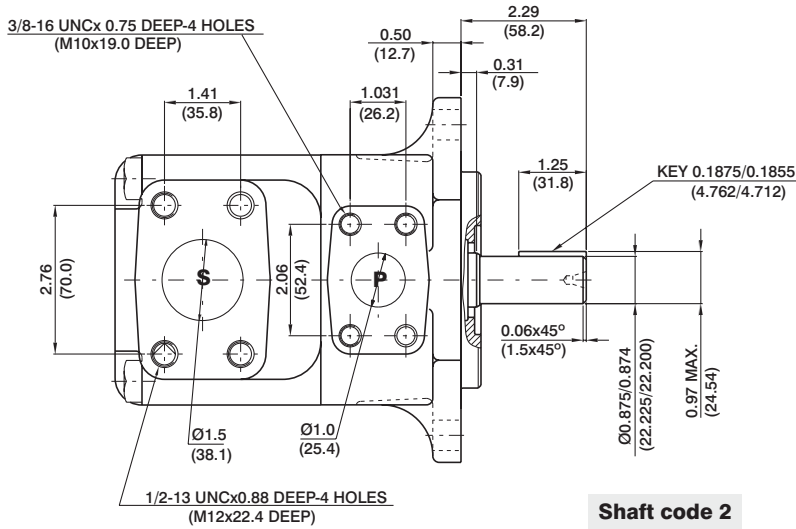

Shaft code 2
(Keyed no SAE)

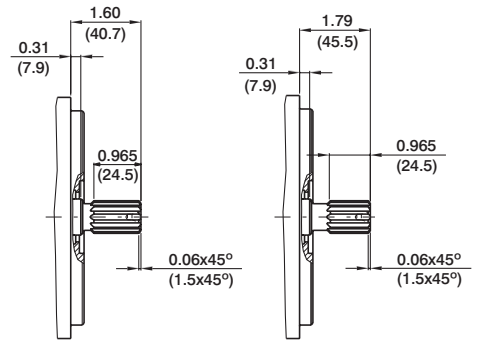

Shaft code 3
SAE B splined shaft
Class 1-J498b
16/32 dp. 13 teeth
30° pressure angle
flat root side fit

Shaft code 4
SAE BB splined shaft
Class 1-J498b
16/32 dp. 15 teeth
30° pressure angle
flat root side fit

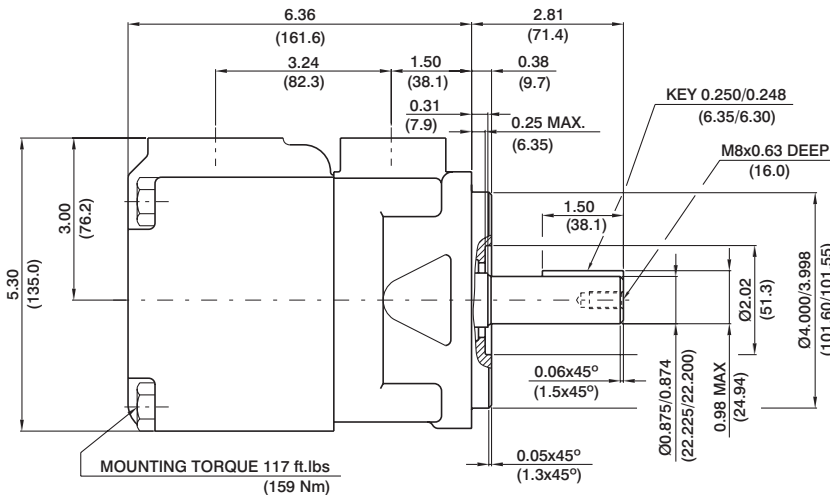

Shaft code 1
(Keyed SAE B)

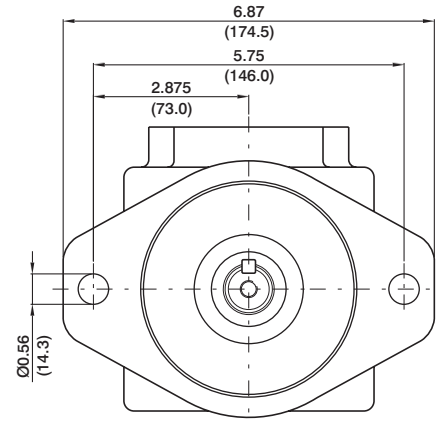

Shaft torque limits in ³ /rev x psi (ml/rev x bar)	
Shaft	Vp x p max.
1	14473 (16500)
2	12666 (14300)
3	18246 (20600)
4	19309 (21821)

OPERATING CHARACTERISTICS - TYPICAL (24 cST)

Pressure port	Series	Volumetric Displacement Vp		Flow q & n = 1500 rpm						Input power p & n = 1500 rpm					
				p = 0 bar (0 psi)		p = 140 bar (2000 psi)		p = 240 bar (3500 psi)		p = 7 bar (100 psi)		p = 140 bar (2000 psi)		p = 240 bar (3500 psi)	
		in ³ /rev	cm ³ /rev	gpm	lpm	gpm	lpm	gpm	lpm	hp	kw	hp	kw	hp	kw
VT6C	003	0.66	10.8	4.29	16.2	2.96	11.2	2.04	7.7	1.74	1.3	7.11	5.3	11.26	8.4
	005	1.05	17.2	6.83	25.8	5.50	20.8	4.57	17.3	1.88	1.4	10.06	7.5	16.36	12.2
	006	1.30	21.3	8.44	31.9	7.11	26.9	6.19	23.4	2.01	1.5	11.94	8.9	19.71	14.7
	008	1.61	26.4	10.48	39.6	9.15	34.6	8.22	31.1	2.15	1.6	14.35	10.7	22.93	17.7
	010	2.08	34.1	13.52	51.1	12.19	46.1	11.26	42.6	2.28	1.7	18.64	13.4	29.90	22.3
	012	2.26	37.1	14.71	55.6	13.36	50.6	12.46	47.1	2.28	1.7	19.31	14.4	32.32	24.1
	014	2.81	46.0	18.25	69.0	16.93	64.0	16.00	60.5	2.55	1.9	23.60	17.6	39.56	29.5
	015	3.08	50.5	20.00	75.6	18.73	73.2	19.02	67.5	2.68	2.0	25.61	19.1	42.91	32.0
	017	3.56	58.3	23.12	87.4	21.79	82.4	20.87	78.9	2.82	2.1	29.37	21.9	49.48	36.9
	020	3.89	63.8	25.32	95.7	23.99	90.7	23.07	87.2	2.95	2.2	31.92	23.8	53.91	40.2
	022	4.29	70.3	27.88	105.4	26.56	100.4	25.63	96.9	3.08	2.3	35.00	26.1	59.14	44.1
	025 ¹⁾	4.84	79.3	31.46	118.9	30.13	113.9	29.21	110.4	3.35	2.5	39.16	29.2	66.38	49.5
	028 ^{1,2)}	5.42	88.8	35.24	133.2	33.92	128.2	33.28	125.8	3.75	2.8	43.85	32.7	72.95	54.5
031 ^{1,2)}	6.10	100.0	39.68	150.0	38.35	145.0	37.72	142.6	3.75	2.8	48.95	36.5	80.95	61.0	

1) 025-028-031 = 2500 RPM. max.

2) 028-031 = 210 bar (3000 psi) max. int.

VT6CSH W * - 022 - 1 R 00 - B 1 - 00 *

Series

Use for severe duty shaft only

One letter can be added to specify special parts in series

Cam ring

Volumetric displacement cm^3/rev (in^3/rev)

*003/B03/Y03 = 10.8 (0.66)	015/B15/Y15 = 50.5 (3.08)
005/B05/Y05 = 17.2 (1.05)	017/B17/Y17 = 58.3 (3.56)
006/B06/Y06 = 21.3 (1.30)	020/B20/Y20 = 63.8 (3.89)
008/B08/Y08 = 26.4 (1.61)	022/B22/Y22 = 70.3 (4.29)
010/B10/Y10 = 34.1 (2.08)	025/B25/Y25 = 79.3 (4.84)
012/B12/Y12 = 37.1 (2.26)	028/B28/Y28 = 88.8 (5.42)
014/B14/Y14 = 46.0 (2.81)	031/B31/Y31 = 100.0 (6.10)

*'0' - Uni - directional 'B' - Bi - directional 'Y' - Bi - directional for cold start

Type of shaft

- 1 - Keyed (SAE B)
- 3 - Splined (SAE B)
- 4 - Splined (SAE BB)

Severe duty shaft VT6CSHW

- 5 - Keyed (SAE BB)

Modifications

Mounting W/connection variables

	UNC		METRIC	
	00	01	M0	M1
P	1"	3/4"	1"	3/4"
S	1 1/2"			

Seal class

- 1 - S1 (for mineral oil)
- 4 - S4 (for fire resistant fluids)
- 5 - S5 (for mineral oil and fire resistant fluids)

Design letter

Porting combination

00 - standard

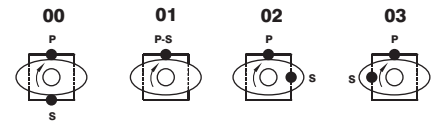

S - Suction port P - Pressure port

Direction of rotation (view on shaft end)

- R - clockwise
- L - counter-clockwise

INTERNAL LEAKAGE (TYPICAL)

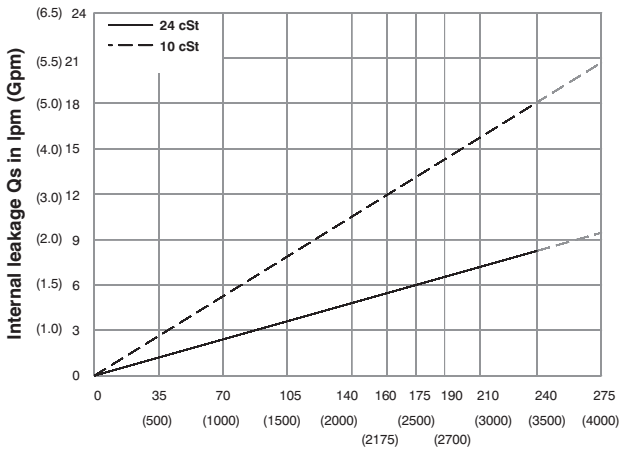

Pressure in bar (psi)

Do not operate pump more than 5 seconds at any speed or viscosity if internal leakage is more than 50% of theoretical flow.

NOISE LEVEL (TYPICAL)

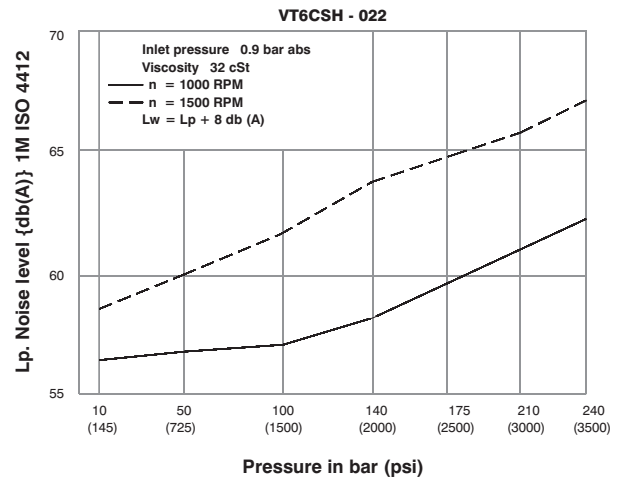

Pressure in bar (psi)

HYDROMECHANICAL POWER LOSS (TYPICAL)

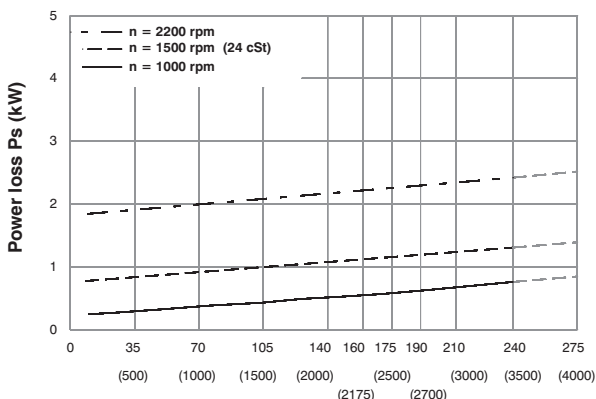

Pressure in bar (psi)

PERMISSIBLE RADIAL LOAD

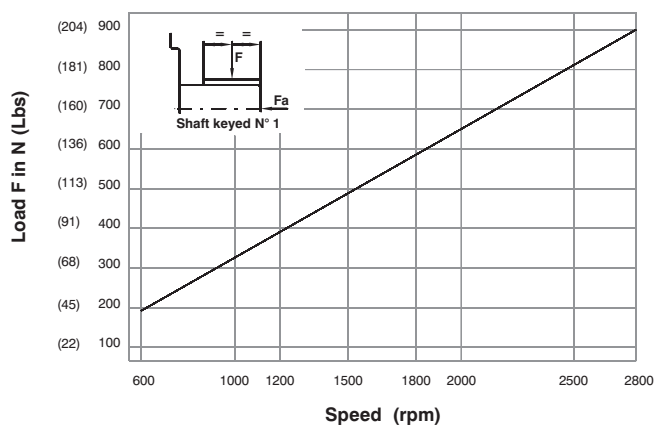

Maximum axial load permissible $F_a = 800 \text{ N}$ (180 Lbs)

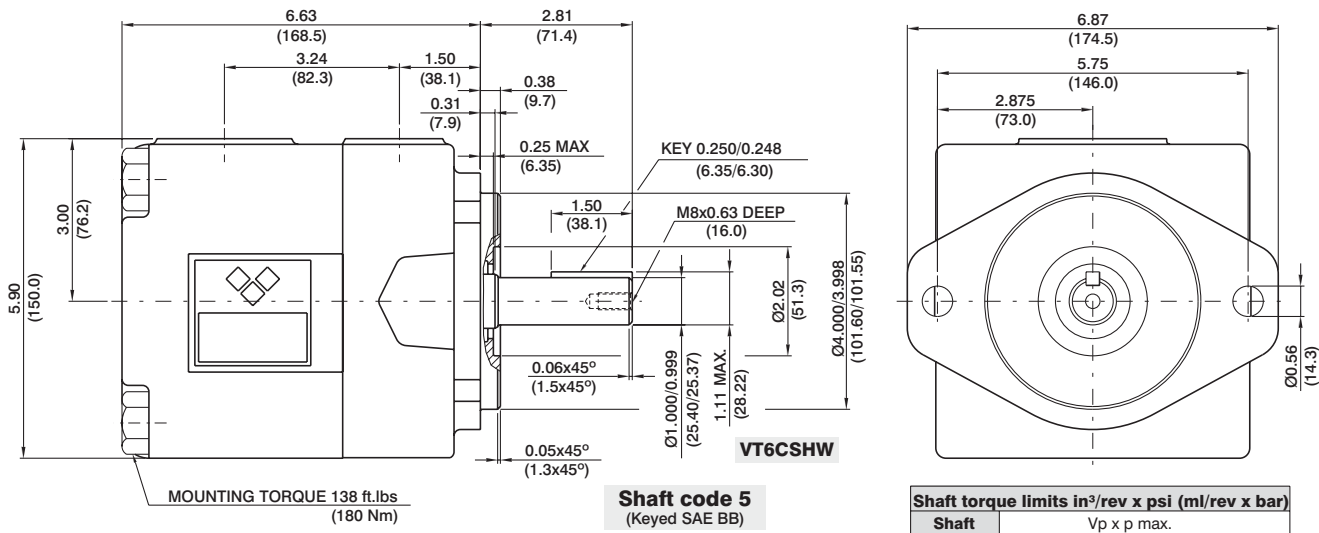
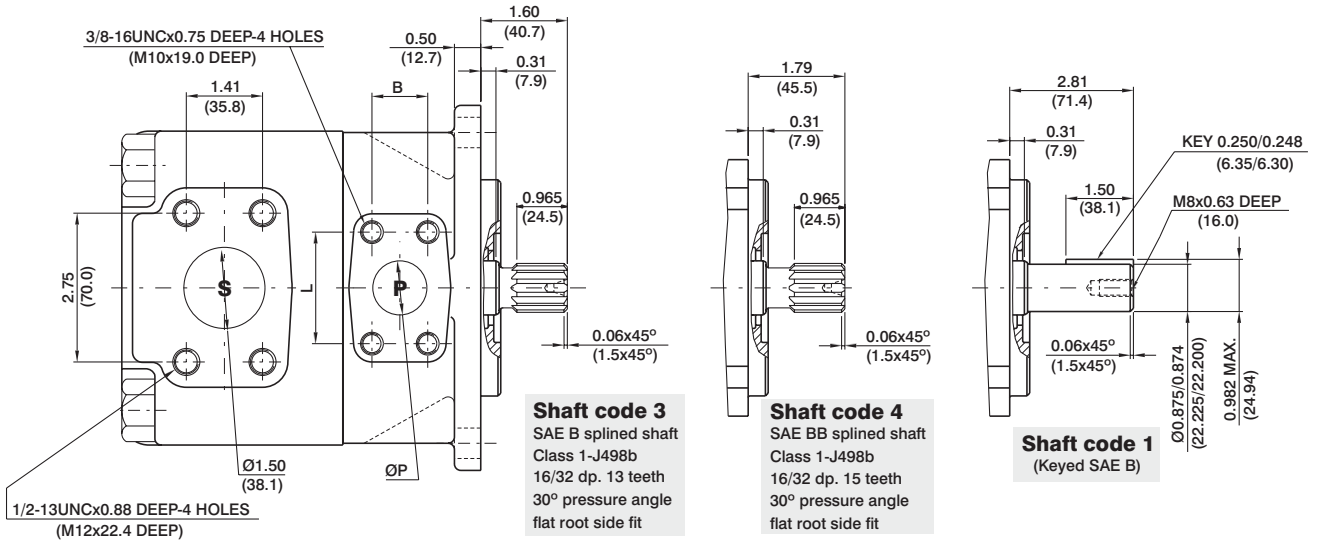

ØP	L	B
0.75 (19.05)	1.87 (47.6)	0.87 (22.2)
1.00 (25.4)	2.06 (52.4)	1.03 (26.2)

Shaft code 5
(Keyed SAE BB)

Shaft torque limits in ³ /rev x psi (ml/rev x bar)	
Shaft	Vp x p max.
1	14473 (16500)
3	18246 (20600)
4	19309 (21821)
5	18945 (21420)

OPERATING CHARACTERISTICS - TYPICAL (24 cST)

Pressure port	Series	Volumetric Displacement Vp		Flow q & n = 1500 rpm						Input power p & n = 1500 rpm					
				p = 0 bar (0 psi)		p = 140 bar (2000 psi)		p = 240 bar (3500 psi)		p = 7 bar (100 psi)		p = 140 bar (2000 psi)		p = 240 bar (3500 psi)	
		in ³ /rev	cm ³ /rev	gpm	lpm	gpm	lpm	gpm	lpm	hp	kw	hp	kw	hp	kw
VT6CSH	003	0.66	10.8	4.29	16.2	2.96	11.2	2.04	7.7	1.74	1.3	7.11	5.3	11.26	8.4
	005	1.05	17.2	6.83	25.8	5.50	20.8	4.57	17.3	1.88	1.4	10.06	7.5	16.36	12.2
	006	1.30	21.3	8.44	31.9	7.11	26.9	6.19	23.4	2.01	1.5	11.94	8.9	19.71	14.7
	008	1.61	26.4	10.48	39.6	9.15	34.6	8.22	31.1	2.15	1.6	14.35	10.7	22.93	17.7
	010	2.08	34.1	13.52	51.1	12.19	46.1	11.26	42.6	2.28	1.7	18.64	13.4	29.90	22.3
	012	2.26	37.1	14.71	55.6	13.36	50.6	12.46	47.1	2.28	1.7	19.31	14.4	32.32	24.1
	014	2.81	46.0	18.25	69.0	16.93	64.0	16.00	60.5	2.55	1.9	23.60	17.6	39.56	29.5
	015	3.08	50.5	20.00	75.6	18.73	73.2	19.02	67.5	2.68	2.0	25.61	19.1	42.91	32.0
	017	3.56	58.3	23.12	87.4	21.79	82.4	20.87	78.9	2.82	2.1	29.37	21.9	49.48	36.9
	020	3.89	63.8	25.32	95.7	23.99	90.7	23.07	87.2	2.95	2.2	31.92	23.8	53.91	40.2
	022	4.29	70.3	27.88	105.4	26.56	100.4	25.63	96.9	3.08	2.3	35.00	26.1	59.14	44.1
	025 ¹⁾	4.84	79.3	31.46	118.9	30.13	113.9	29.21	110.4	3.35	2.5	39.16	29.2	66.38	49.5
	028 ^{1,2)}	5.42	88.8	35.24	133.2	33.92	128.2	33.28	125.8	3.75	2.8	43.85	32.7	72.95	54.5
031 ^{1,2)}	6.10	100.0	39.68	150.0	38.35	145.0	37.72	142.6	3.75	2.8	48.95	36.5	79.95	59.4	

1) 025-028-031 = 2500 RPM. max.

2) 028-031 = 210 bar (3000 psi) max. int.

Series **VT6D** * * - **045** - **1** **R** **00** - **B** **1** *

N - Shaft seal installed reverse
Q - Special mounting cap with ear orientation of 20° from standard
Y - Metric port connection (not for code 'Q')
 Omit for UNC

Cam ring
 Volumetric displacement cm³/rev (in³/rev)

*014/B14 = 47.6 (2.90)	035/B35 = 111.0 (6.77)
017/B17 = 58.2(3.55)	038/B38 = 120.3 (7.34)
020/B20 = 66.0 (4.03)	042/B42 = 136.0 (8.30)
024/B24 = 79.5 (4.85)	045/B45 = 145.7 (8.89)
028/B28 = 89.7 (5.47)	050/B50 = 158.0 (9.64)
031/B31 = 98.3 (6.00)	061/B61 = 190.5 (11.62)

*'0' - Uni - directional 'B' - Bi - directional

Type of shaft

- 1 - keyed (SAE C)
- 2 - keyed (no SAE)
- 3 - splined (SAE C)
- 4 - splined (no SAE)

Modifications

Seal class

- 1 - S1 (for mineral oil)
- 4 - S4 (for fire resistant fluids)
- 5 - S5 (for mineral oil and fire resistant fluids)

Design letter

Porting combination

00 - standard

00	01	02	03

S - Suction port **P** - Pressure port

Direction of rotation (view on shaft end)

R - clockwise
 L - counter-clockwise

INTERNAL LEAKAGE (TYPICAL)

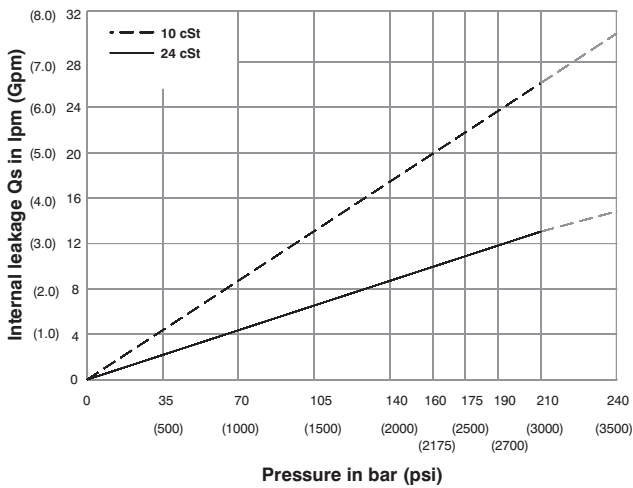

NOISE LEVEL (TYPICAL)

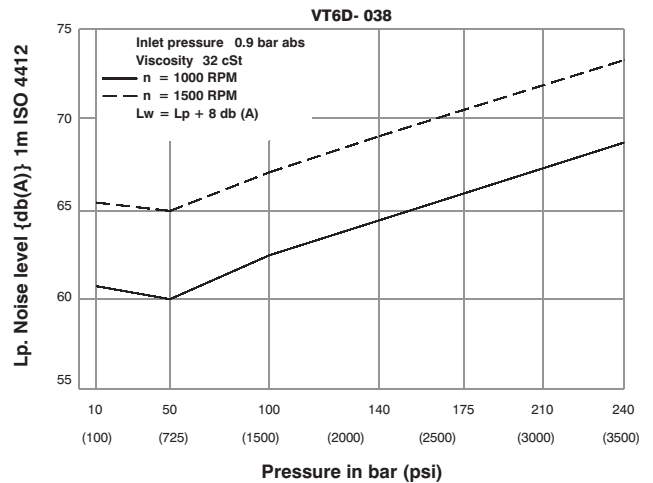

HYDROMECHANICAL POWER LOSS (TYPICAL)

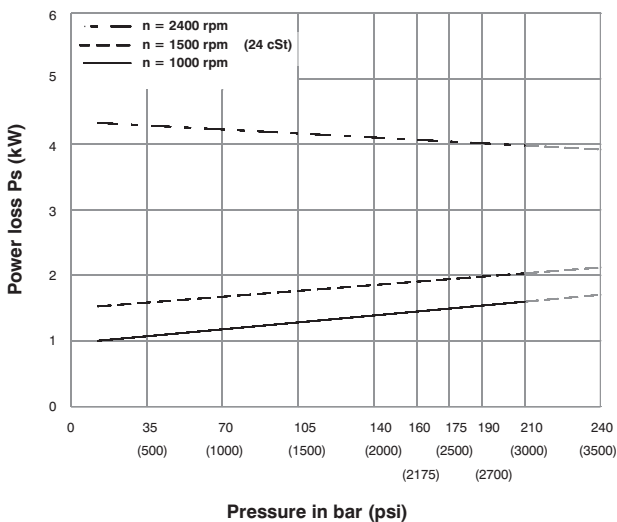

PERMISSIBLE RADIAL LOAD

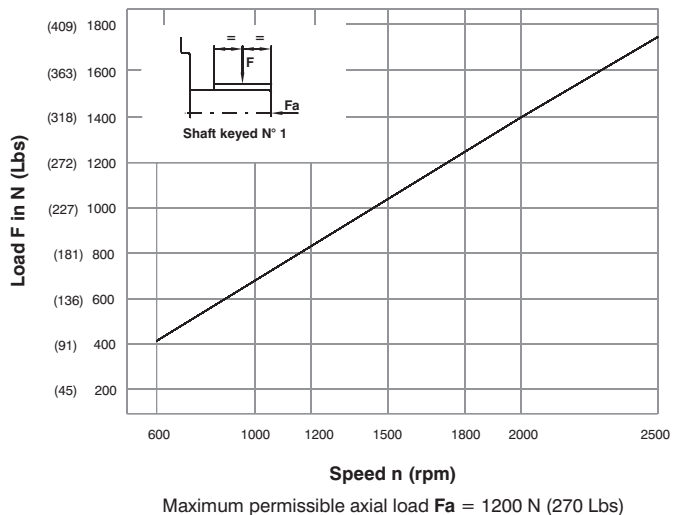

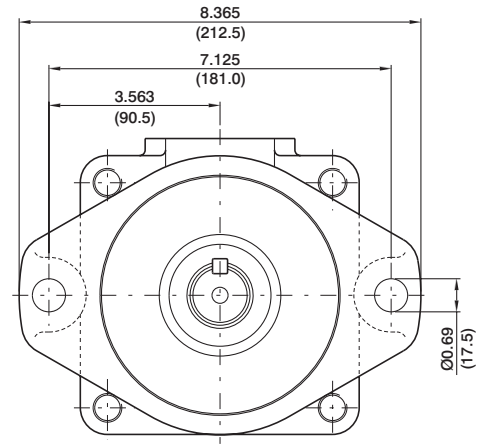
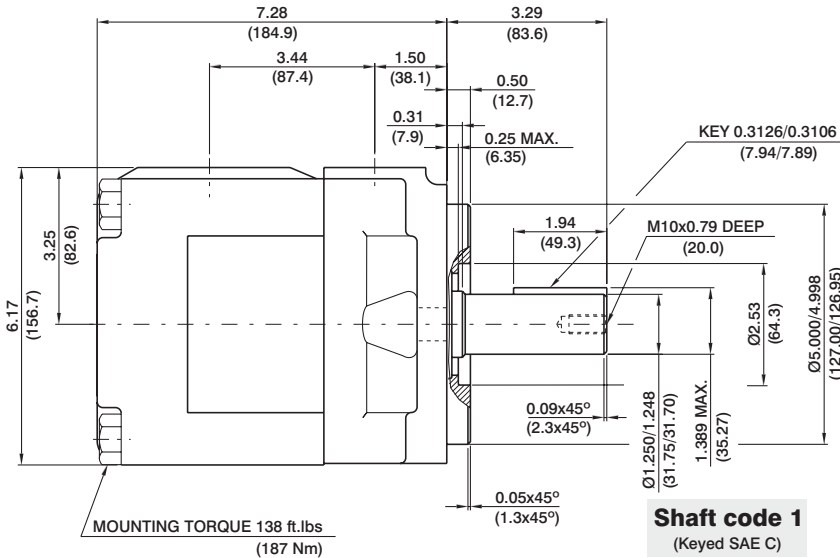
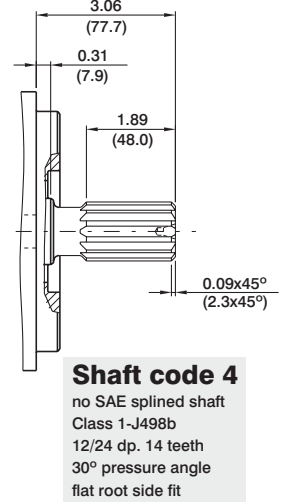
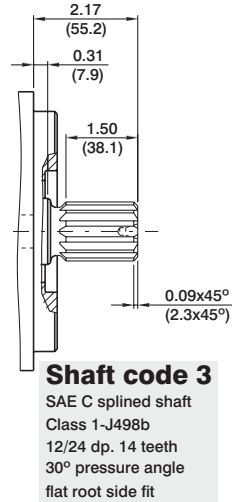
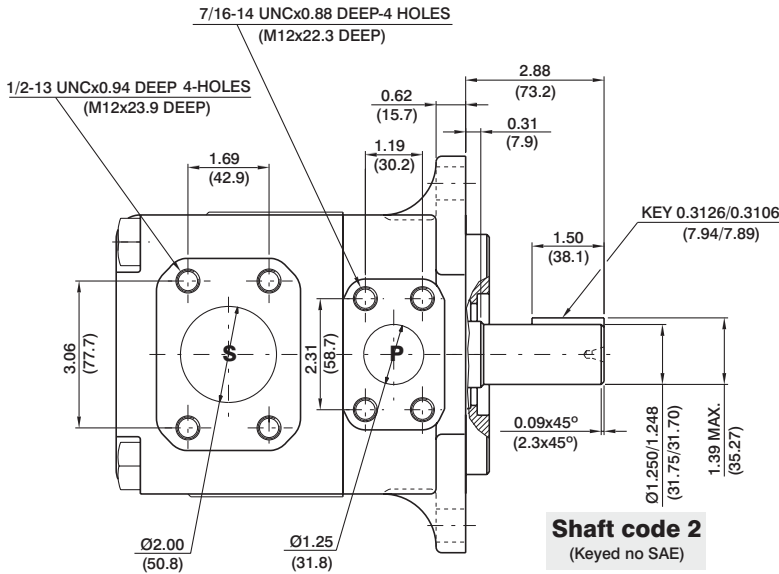

Shaft torque limits in ³ /rev x psi (ml/rev x bar)	
Shaft	Vp x p max.
1	38299 (43283)
2	30638 (34590)
3	54207 (61200)
4	54207 (61200)

OPERATING CHARACTERISTICS - TYPICAL (24 cST)

Pressure port	Series	Volumetric Displacement Vp		Flow q & n = 1500 rpm						Input power p & n = 1500 rpm					
				p = 0 bar (0 psi)		p = 140 bar (2000 psi)		p = 240 bar (3500 psi)		p = 7 bar (100 psi)		p = 140 bar (2000 psi)		p = 240 bar (3500 psi)	
		in ³ /rev	cm ³ /rev	gpm	lpm	gpm	lpm	gpm	lpm	hp	kw	hp	kw	hp	kw
VT6D VT6DQ VT6DN	014	2.90	47.6	18.88	71.4	16.42	62.1	14.78	55.9	3.08	2.3	24.81	18.5	41.03	30.6
	017	3.55	58.2	23.1	87.3	20.6	78.0	18.99	71.8	3.35	2.5	29.77	22.2	49.62	37.0
	020	4.00	66.0	26.19	99.0	23.73	89.7	22.08	83.5	3.75	2.8	33.39	24.9	55.92	41.7
	024	4.80	79.5	31.56	119.3	29.10	110.0	27.46	103.8	4.02	3.0	39.69	29.6	66.78	49.8
	028	5.50	89.7	35.58	134.5	33.12	125.2	31.48	119.0	4.29	3.2	44.52	33.2	74.96	55.9
	031	6.00	98.3	39.00	147.5	36.53	138.1	34.89	131.9	4.42	3.3	48.54	36.2	81.80	61.0
	035	6.80	111.0	44.04	166.5	41.58	157.2	39.94	151.0	4.69	3.5	54.58	40.7	92.13	68.7
	038	7.30	120.3	47.72	180.4	45.26	171.1	43.62	164.9	4.96	3.7	58.87	43.9	99.64	74.3
	042 ¹⁾	8.30	136.0	53.96	204.0	51.50	194.7	49.86	188.5	5.36	4.0	66.25	49.4	112.24	83.7
	045 ¹⁾	8.89	145.7	57.80	218.5	55.34	209.2	53.70	203.0	5.50	4.1	70.81	52.8	120.02	89.5
	050 ^{1,2)}	9.64	158.0	62.69	237.0	60.23	227.7	59.25	224.0	5.90	4.4	76.44	57.0	113.98	85.0
061 ^{1,3)}	11.62	190.5	76.25	285.7	73.54	278.0	--	--	6.16	4.6	81.26	60.6	--	--	

1) 042-045-050-061=2200 RPM max.

2) 050=210 bar (3000 psi) max. int.

3) 061 = 120 bar (1740 psi) max. int, 061 = 80 bar (1160 psi) cont.

Series VT6E * - 066 - 3 R 00 - A 1 *

Y - Metric port connection, Omit for UNC

Cam ring

Volumetric displacement cm^3/rev (in^3/rev)

042 = 132.3 (8.07)
 045 = 142.4 (8.69)
 050 = 158.5 (9.67)
 052 = 164.8 (10.06)
 057 = 180.7 (11.02)
 062 = 196.7 (12.00)
 066 = 213.3 (13.02)
 072 = 227.1 (13.86)
 085 = 269.8 (16.46)

Type of shaft

1 - keyed (SAE CC)
 2 - keyed (no SAE)
 3 - splined (SAE C)
 4 - splined (SAE CC)

Modifications

Seal class

- 1 - S1 (for mineral oil)
- 4 - S4 (for fire resistant fluids)
- 5 - S5 (for mineral oil and fire resistant fluids)

Design letter

Porting combination

00 - standard

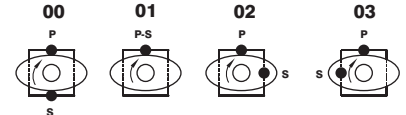

S - Suction port P - Pressure port

Direction of rotation (view on shaft end)

- R - clockwise
- L - counter-clockwise

INTERNAL LEAKAGE (TYPICAL)

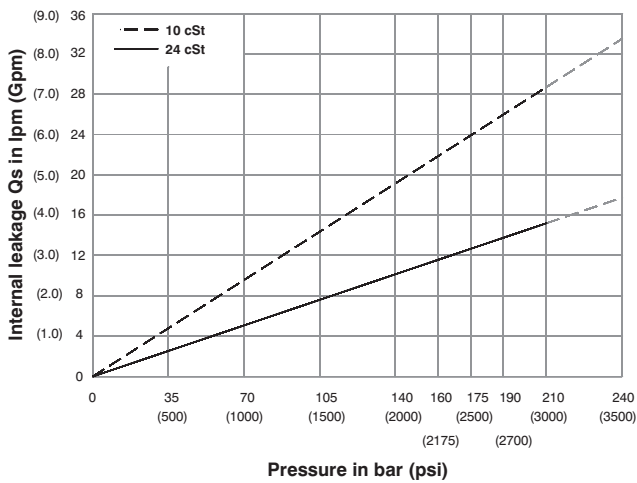

NOISE LEVEL (TYPICAL)

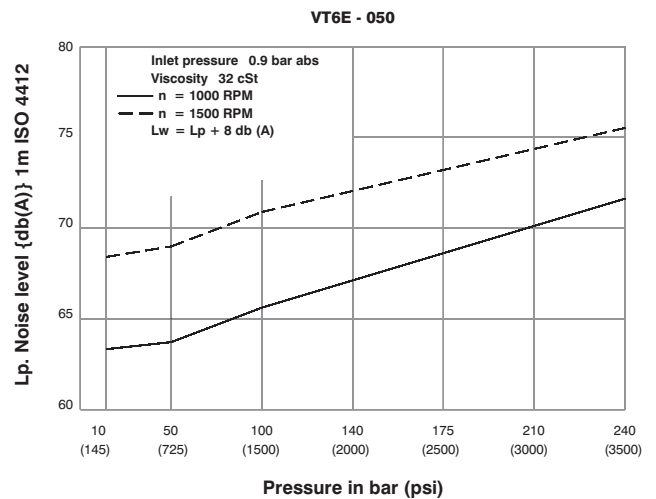

HYDROMECHANICAL POWER LOSS (TYPICAL)

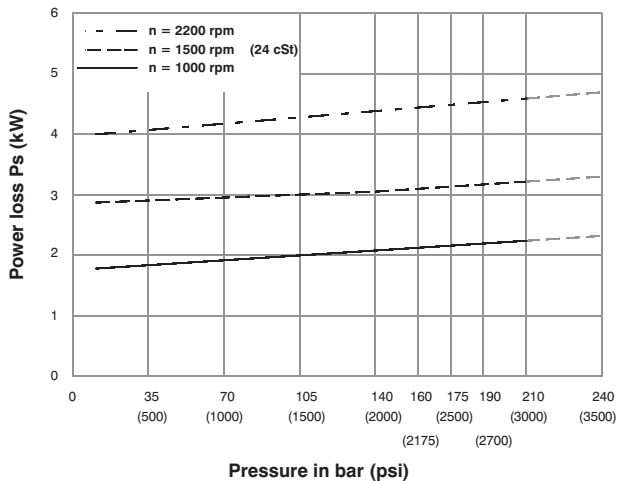

PERMISSIBLE RADIAL LOAD

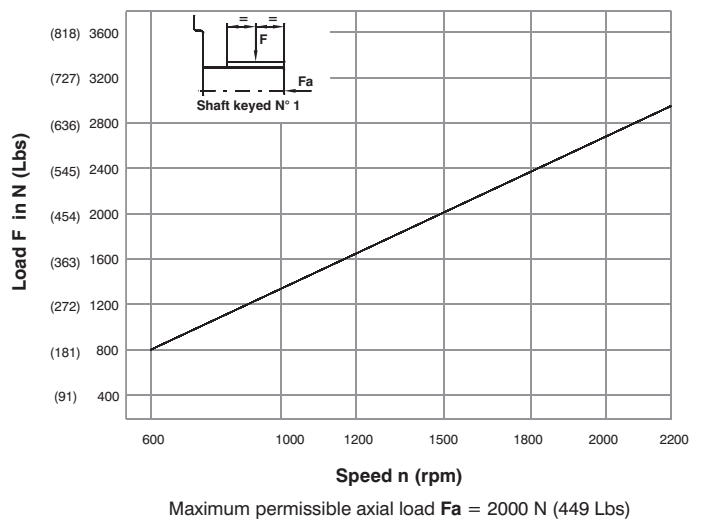

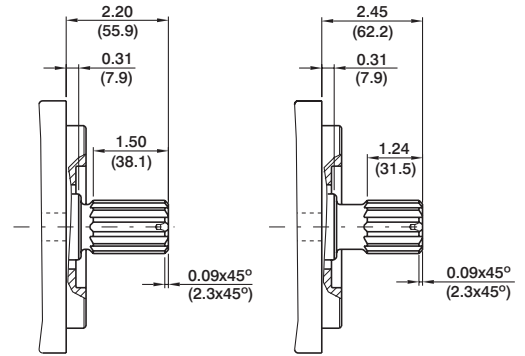
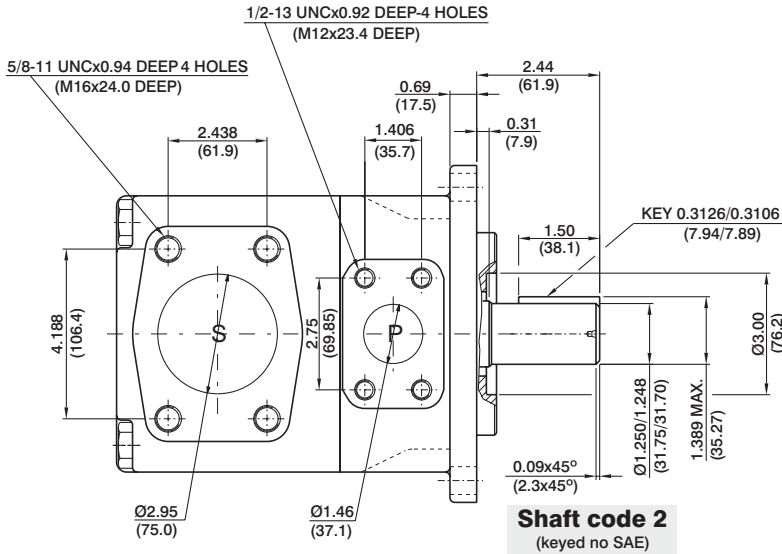

Shaft code 3
SAE C splined shaft
Class 1-J498b
12/24 dp, 14 teeth
30° pressure angle
flat root side fit

Shaft code 4
SAE CC splined shaft
Class 1-J498b
12/24 dp, 17 teeth
30° pressure angle
flat root side fit

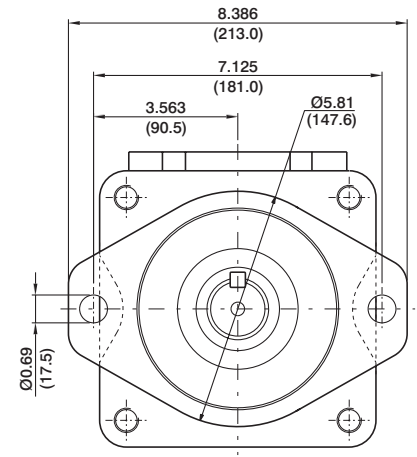
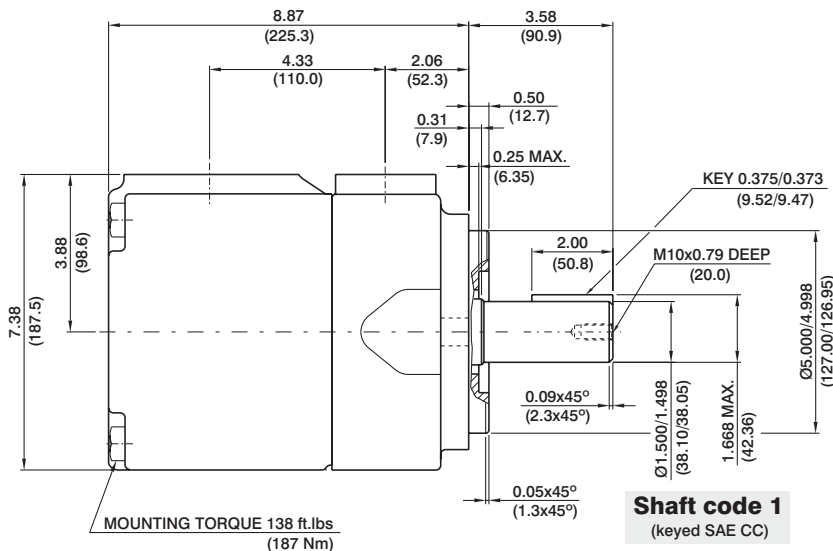

Shaft torque limits in ³ /rev x psi (ml/rev x bar)	
Shaft	Vp x p max.
1	48273 (54555)
2	30638 (34590)
3	54207 (61200)
4	54207 (61200)

OPERATING CHARACTERISTICS - TYPICAL (24 cST)

Pressure port	Series	Volumetric Displacement Vp		Flow q & n = 1500 rpm						Input power p & n = 1500 rpm					
				p = 0 bar (0 psi)		p = 140 bar (2000 psi)		p = 240 bar (3500 psi)		p = 7 bar (100 psi)		p = 140 bar (2000 psi)		p = 240 bar (3500 psi)	
		in ³ /rev	cm ³ /rev	gpm	lpm	gpm	lpm	gpm	lpm	hp	kw	hp	kw	hp	kw
VT6E	042	8.07	132.3	52.50	198.5	49.87	188.5	47.96	181.3	6.97	5.2	66.25	49.4	110.77	82.6
	045	8.70	142.4	56.51	213.6	53.86	203.6	51.98	196.5	7.24	5.4	70.94	52.9	118.95	88.7
	050	9.67	158.5	62.88	237.7	60.24	227.7	58.36	220.6	7.64	5.7	78.45	58.5	131.82	98.3
	052	10.00	164.8	65.40	247.2	62.75	237.2	60.87	230.1	7.78	5.8	81.53	60.8	136.92	102.1
	057	11.02	180.7	71.71	271.1	69.07	261.1	67.19	254.0	8.18	6.1	89.04	66.4	143.35	106.9
	062	12.00	196.7	78.04	295.0	75.40	285.0	73.52	277.9	8.58	6.4	96.42	71.9	162.67	121.3
	066	13.00	213.3	84.63	319.9	81.98	309.9	80.11	302.8	8.98	6.7	104.20	77.7	175.94	131.2
	072	13.86	227.1	90.11	340.6	87.46	330.6	85.58	323.5	9.25	6.9	110.77	82.6	187.07	139.5
	085 ^{1,2)}	16.40	269.8	107.00	404.7	105.21	397.7	--	--	9.78	7.3	87.56	65.3	--	--

1) 085 = 2000 RPM max.

2) 085 = 75 bar (1100 psi) cont.

085 = 90 bar (1300 psi) max. int.

Series VT6CM * - B22 - 1 R 00 - C 1 *

Y - Metric port connection, Omit for UNC

Cam ring

Volumetric displacement cm^3/rev (in^3/rev)

* B03/R03 = 10.8 (0.66)	B15/R15 = 50.5 (3.08)
B05/R05 = 17.2 (1.05)	B17/R17 = 58.3 (3.56)
B06/R06 = 21.3 (1.30)	B20/R20 = 63.8 (3.89)
B08/R08 = 26.4 (1.61)	B22/R22 = 70.3 (4.29)
B10/R10 = 34.1 (2.08)	B25/R25 = 79.3 (4.84)
B12/R12 = 37.1 (2.26)	B28/R28 = 88.8 (5.42)
B14/R14 = 46.0 (2.81)	B31/R31 = 100.0 (6.10)

* 'B' - for Mobile
'R' - for Mobile - spring assisted

Type of shaft

- 1 - keyed (SAE B)
- 2 - keyed (no SAE)
- 3 - splined (SAE B)
- 4 - splined (SAE BB)

Modifications

Seal class

- 1 - S1 (for mineral oil)
- 4 - S4 (for fire resistant fluids)
- 5 - S5 (for mineral oil and fire resistant fluids)

Design letter

Porting combination

00 - standard

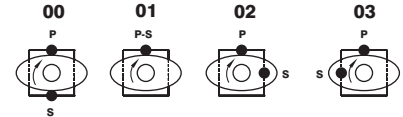

S - Suction port P - Pressure port

Direction of rotation (view on shaft end)

- R - clockwise
- L - counter-clockwise

INTERNAL LEAKAGE (TYPICAL)

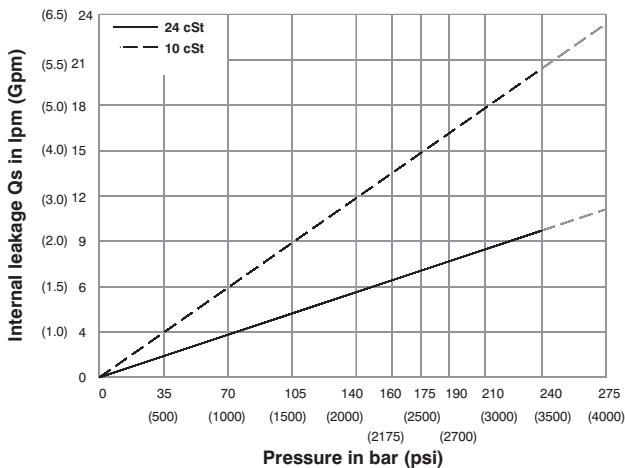

Do not operate pump more than 5 seconds at any speed or viscosity if internal leakage is more than 50% of theoretical flow.

NOISE LEVEL (TYPICAL)

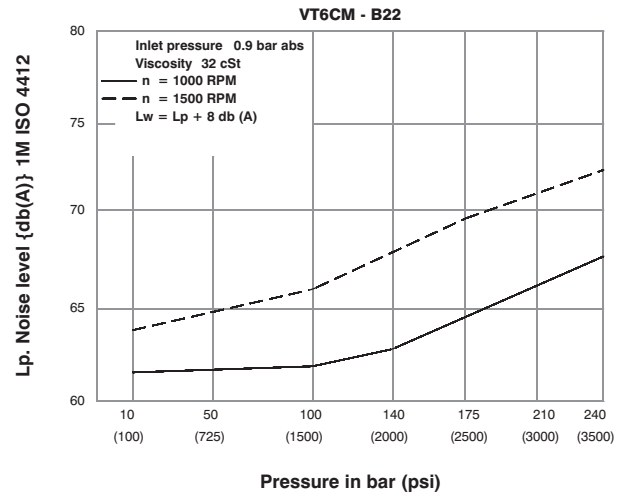

HYDROMECHANICAL POWER LOSS (TYPICAL)

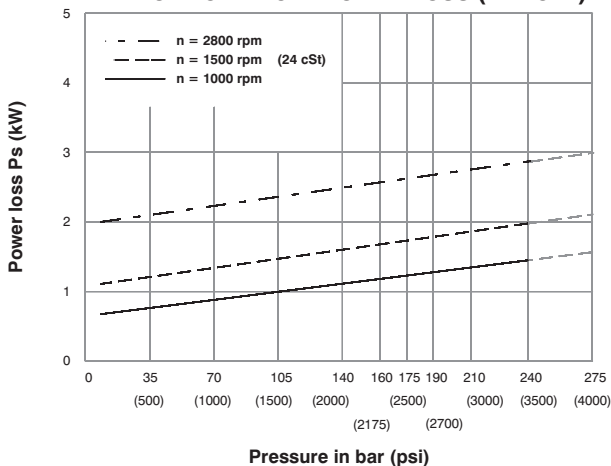

PERMISSIBLE RADIAL LOAD

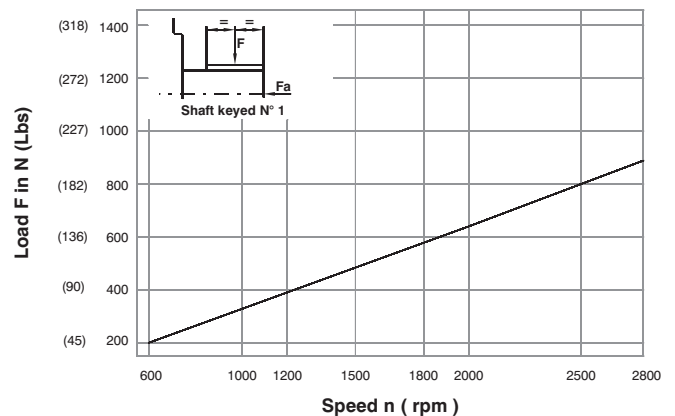

Maximum axial load permissible $F_a = 800 \text{ N}$ (180 Lbs)

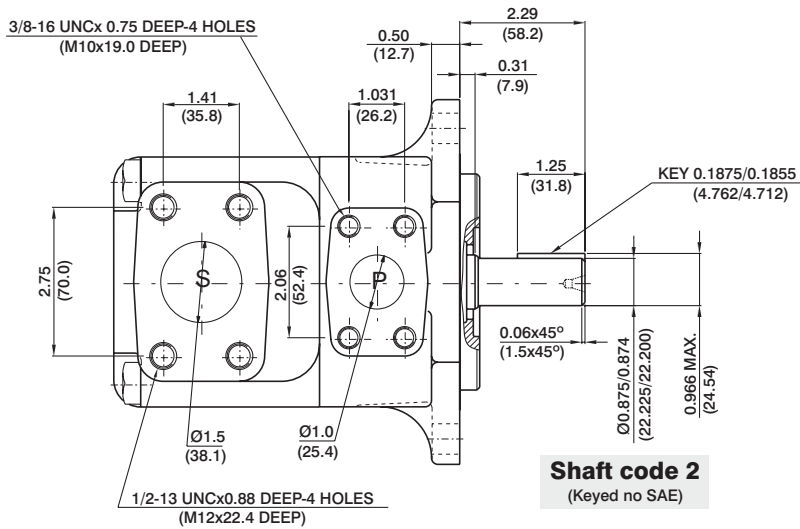

Shaft code 2
(Keyed no SAE)

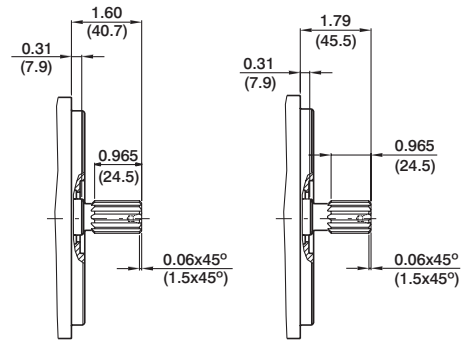

Shaft code 3
SAE B splined shaft
Class 1-J498b
16/32 dp. 13 teeth
30° pressure angle
flat root side fit

Shaft code 4
SAE BB splined shaft
Class 1-J498b
16/32 dp. 15 teeth
30° pressure angle
flat root side fit

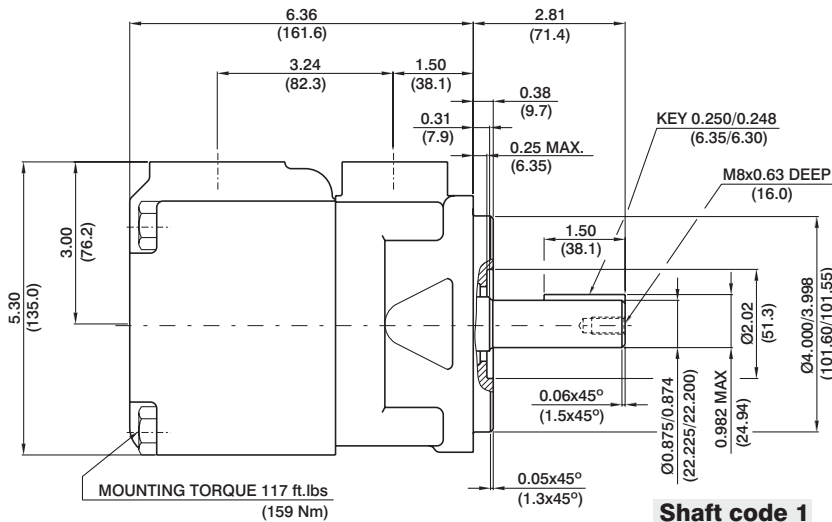

Shaft code 1
(Keyed SAE B)

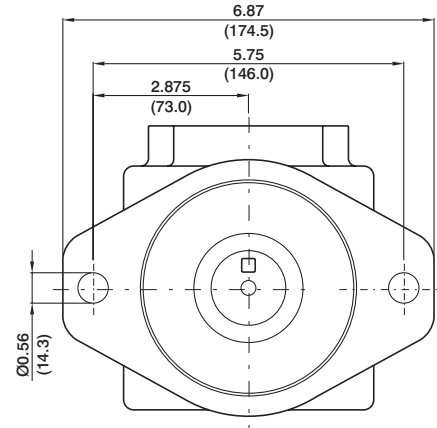

Shaft torque limits in ³ /rev x psi (ml/rev x bar)	
Shaft	V _p x p max.
1	14473 (16500)
2	12666 (14300)
3	18246 (20600)
4	19309 (21821)

OPERATING CHARACTERISTICS - TYPICAL (24 cST)

Pressure port	Series	Volumetric Displacement V _p		Flow q & n = 1500 rpm						Input power p & n = 1500 rpm					
		in ³ /rev	cm ³ /rev	p = 0 bar (0 psi)		p = 140 bar (2000 psi)		p = 240 bar (3500 psi)		p = 7 bar (100 psi)		p = 140 bar (2000 psi)		p = 240 bar (3500 psi)	
				gpm	lpm	gpm	lpm	gpm	lpm	hp	kw	hp	kw	hp	kw
VT6CM	B03	0.66	10.8	4.29	16.2	2.83	10.7	--	--	1.74	1.3	7.11	5.3	--	--
	B05	1.05	17.2	6.83	25.8	5.37	20.3	4.17	15.8	1.88	1.4	10.06	7.5	16.36	12.2
	B06	1.30	21.3	8.44	31.9	7.01	26.5	5.82	22.0	2.01	1.5	11.94	8.9	19.71	14.7
	B08	1.61	26.4	10.48	39.6	9.02	34.1	7.83	29.6	2.15	1.6	14.35	10.7	22.93	17.7
	B10	2.08	34.1	13.52	51.1	12.08	45.7	10.89	41.2	2.28	1.7	18.64	13.4	29.90	22.3
	B12	2.26	37.1	14.71	55.6	13.28	50.2	12.08	45.7	2.28	1.7	19.31	14.4	32.32	24.1
	B14	2.81	46.0	18.25	69.0	16.79	63.5	15.60	59.0	2.55	1.9	23.60	17.6	39.56	29.5
	B15	3.08	50.5	20.00	75.6	18.62	70.4	17.46	66.0	2.68	2.0	25.61	19.1	42.91	32.0
	B17	3.56	58.3	23.12	87.4	21.69	82.0	20.50	77.5	2.82	2.1	29.37	21.9	49.48	36.9
	B20	3.89	63.8	25.32	95.7	23.86	90.2	22.67	85.7	2.95	2.2	31.92	23.8	53.91	40.2
	B22	4.29	70.3	27.88	105.4	26.45	100.0	25.26	95.5	3.08	2.3	35.00	26.1	59.14	44.1
	B25 ¹⁾	4.84	79.3	31.46	118.9	30.02	113.5	28.83	109.0	3.35	2.5	39.16	29.2	66.38	49.5
	B28 ^{1,2)}	5.42	88.8	35.24	133.2	33.78	127.7	32.93	124.5	3.75	2.8	43.85	32.7	65.04	48.5
B31 ^{1,2)}	6.10	100.0	39.68	150.0	38.22	144.5	37.38	141.3	3.75	2.8	48.95	36.5	72.95	54.4	

1) B25-B28-B31 = 2500 R.P.M. max.

2) B28-B31 = 210 bar (3000 psi) max. int.

-- Not to use because internal leakage greater than 50% theoretical flow.

VT6GC - B22 - 6 R 00 - A 1 - 00 -

Series

Cam ring

Volumetric displacement cm³/rev (in³/rev)

B03 = 10.8 (0.66)	B15 = 50.5 (3.08)
B05 = 17.2 (1.05)	B17 = 58.3 (3.56)
B06 = 21.3 (1.30)	B20 = 63.8 (3.89)
B08 = 26.4 (1.61)	B22 = 70.3 (4.29)
B10 = 34.1 (2.08)	B25 = 79.3 (4.84)
B12 = 37.1 (2.26)	B28 = 88.8 (5.42)
B14 = 46.0 (2.81)	B31 = 100.0 (6.10)

Type of shaft

6 - splined (DIN 5462)

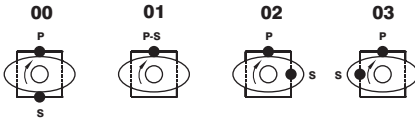

S - Suction port **P** - Pressure port

Modifications

Mounting W/connection variables

- 00 - Flange 1" BSPP
- 01 - Flange 1" SAE 4 bolts (UNC)
- M1 - Flange 1" SAE 4 bolts (METRIC)

Seal class

1 - S1

Design letter

Porting combination

00 - standard

Direction of rotation (view on shaft end)

- R - clockwise
- L - counter-clockwise

INTERNAL LEAKAGE (TYPICAL)

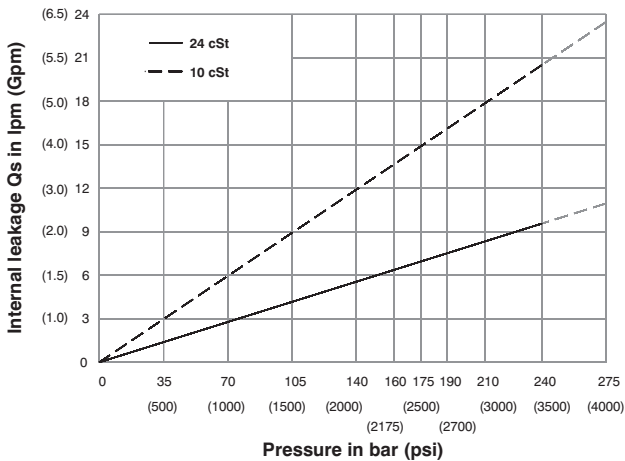

NOISE LEVEL (TYPICAL)

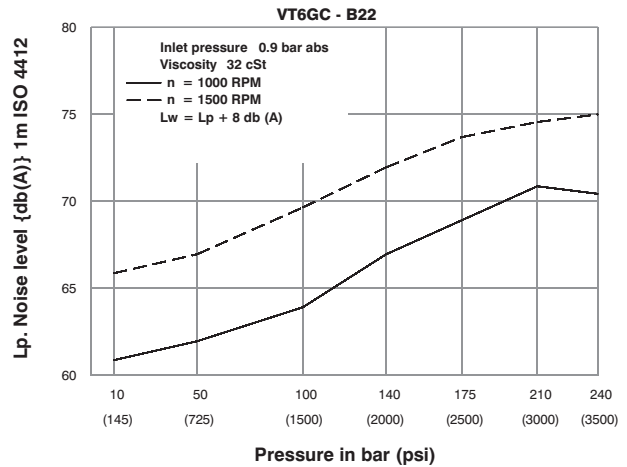

Do not operate pump more than 5 seconds at any speed or viscosity if internal leakage is more than 50% of theoretical flow.

HYDROMECHANICAL POWER LOSS (TYPICAL)

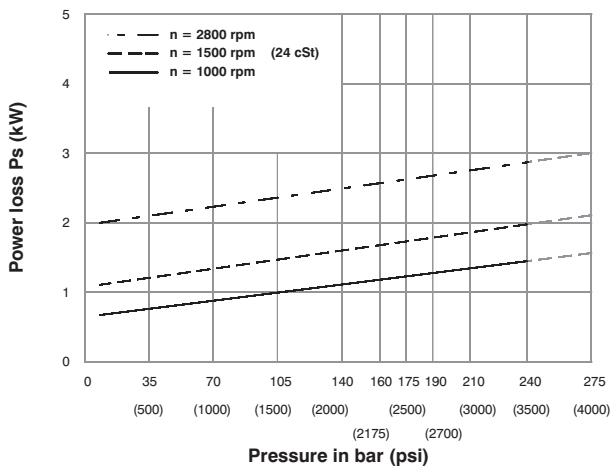

PERMISSIBLE RADIAL LOAD

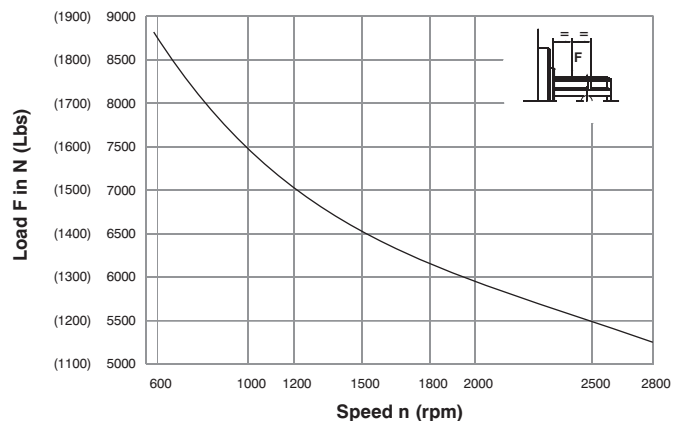

Life time 3000 hours when 70% of the time at 500 N and 30% at max. load.

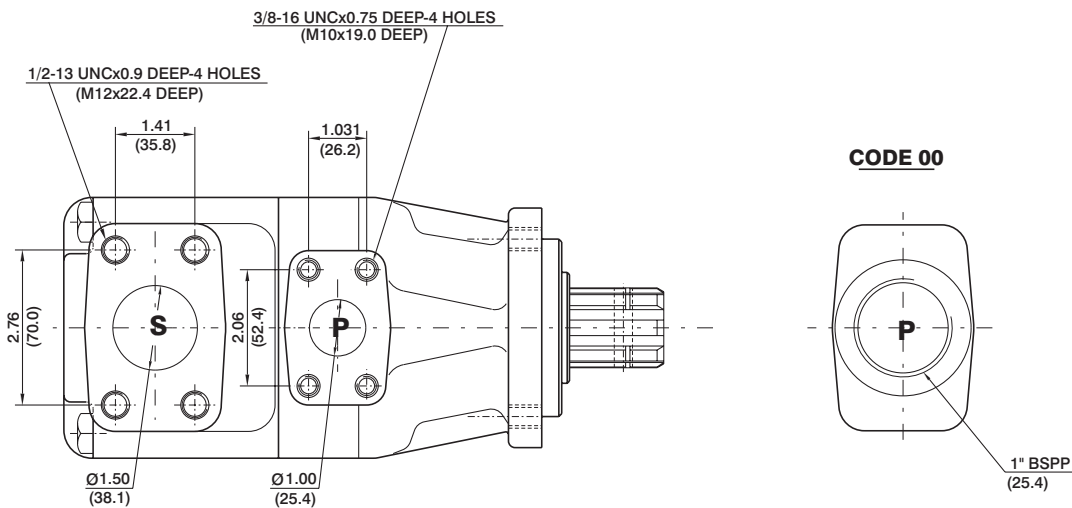
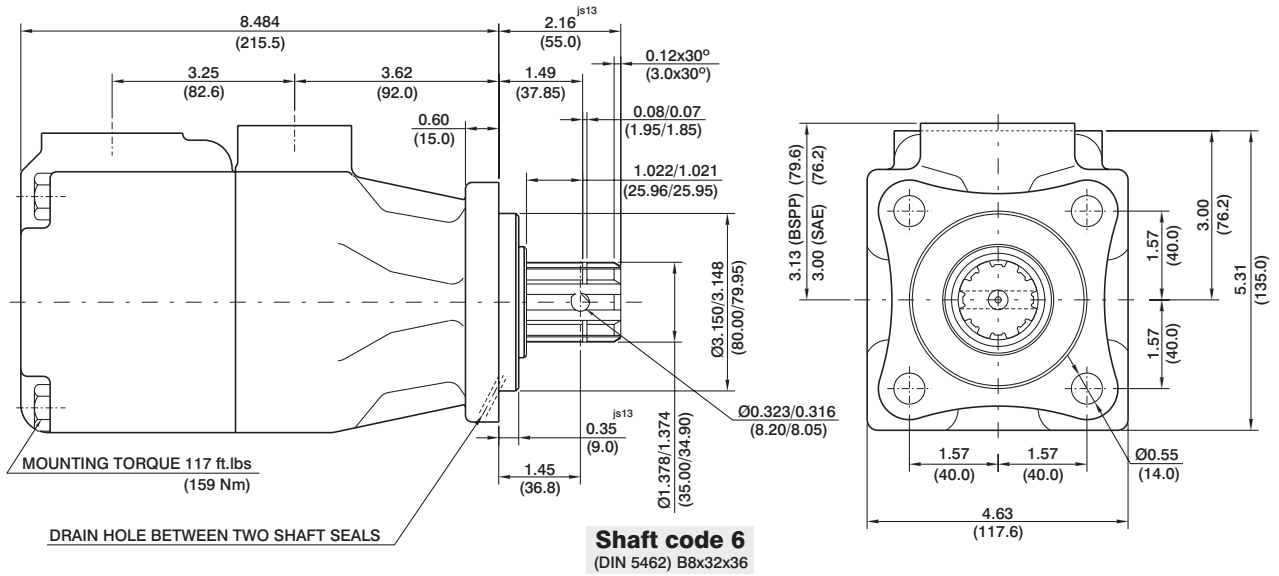

OPERATING CHARACTERISTICS - TYPICAL (24 cST)

Pressure port	Series	Volumetric Displacement Vp		Flow q & n = 1500 rpm						Input power p & n = 1500 rpm					
		in ³ /rev	cm ³ /rev	p = 0 bar (0 psi)		p = 140 bar (2000 psi)		p = 240 bar (3500 psi)		p = 7 bar (100 psi)		p = 140 bar (2000 psi)		p = 240 bar (3500 psi)	
				gpm	lpm	gpm	lpm	gpm	lpm	hp	kw	hp	kw	hp	kw
VT6GC	B03	0.66	10.8	4.29	16.2	2.83	10.7	--	--	1.74	1.3	7.11	5.3	--	--
	B05	1.05	17.2	6.83	25.8	5.37	20.3	4.17	15.8	1.88	1.4	10.06	7.5	16.36	12.2
	B06	1.30	21.3	8.44	31.9	7.01	26.5	5.82	22.0	2.01	1.5	11.94	8.9	19.71	14.7
	B08	1.61	26.4	10.48	39.6	9.02	34.1	7.83	29.6	2.15	1.6	14.35	10.7	22.93	17.7
	B10	2.08	34.1	13.52	51.1	12.08	45.7	10.89	41.2	2.28	1.7	18.64	13.4	29.90	22.3
	B12	2.26	37.1	14.71	55.6	13.28	50.2	12.08	45.7	2.28	1.7	19.31	14.4	32.32	24.1
	B14	2.81	46.0	18.25	69.0	16.79	63.5	15.60	59.0	2.55	1.9	23.60	17.6	39.56	29.5
	B15	3.08	50.5	20.00	75.6	18.62	70.4	17.46	66.0	2.68	2.0	25.61	19.1	42.91	32.0
	B17	3.56	58.3	23.12	87.4	21.69	82.0	20.50	77.5	2.82	2.1	29.37	21.9	49.48	36.9
	B20	3.89	63.8	25.32	95.7	23.86	90.2	22.67	85.7	2.95	2.2	31.92	23.8	53.91	40.2
	B22	4.29	70.3	27.88	105.4	26.45	100.0	25.26	95.5	3.08	2.3	35.00	26.1	59.14	44.1
	B25 ¹⁾	4.84	79.3	31.46	118.9	30.02	113.5	28.83	109.0	3.35	2.5	39.16	29.2	66.38	49.5
	B28 ^{1,2)}	5.42	88.8	35.24	133.2	33.78	127.7	32.93	124.5	3.75	2.8	43.85	32.7	65.04	48.5
	B31 ^{1,2)}	6.10	100.0	39.68	150.0	38.22	144.5	37.38	141.3	3.75	2.8	48.95	36.5	72.95	54.4

1) B25-B28-B31 = 2500 R.P.M. max.

2) B28-B31 = 210 bar (3000 psi) max. int.

-- Not to use because internal leakage greater than 50% theoretical flow.

Series VT6CP - B22 - 2

Cam ring

Volumetric displacement cm^3/rev (in^3/rev)

* B14/R14 = 46.0 (2.81)
 B15/R15 = 50.5 (3.08)
 B17/R17 = 58.3 (3.56)
 B20/R20 = 63.8 (3.89)
 B22/R22 = 70.3 (4.29)
 B25/R25 = 79.3 (4.84)
 B28/R28 = 88.8 (5.42)
 B31/R31 = 100.0 (6.10)

* 'B' - for Mobile
 'R' - for Mobile - spring assisted

Type of shaft

2 - keyed (no SAE)
 3 - splined (SAE C)
 X - splined

Modifications

Seal class

1 - S1 (for mineral oil)
 4 - S4 (for fire resistant fluids)
 5 - S5 (for mineral oil and fire resistant fluids)

Design letter

Porting combination

00 - standard

00

01

02

03

S - Suction port **P** - Pressure port

Direction of rotation (view on shaft end)

R - clockwise
 L - counter-clockwise

INTERNAL LEAKAGE (TYPICAL)

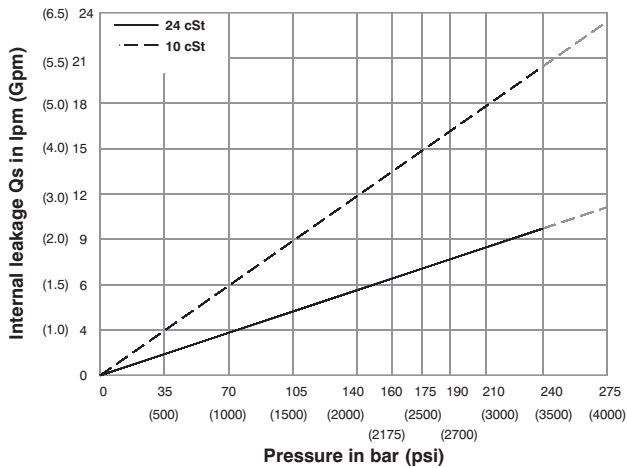

Do not operate pump more than 5 seconds at any speed or viscosity if internal leakage is more than 50% of theoretical flow.

NOISE LEVEL (TYPICAL)

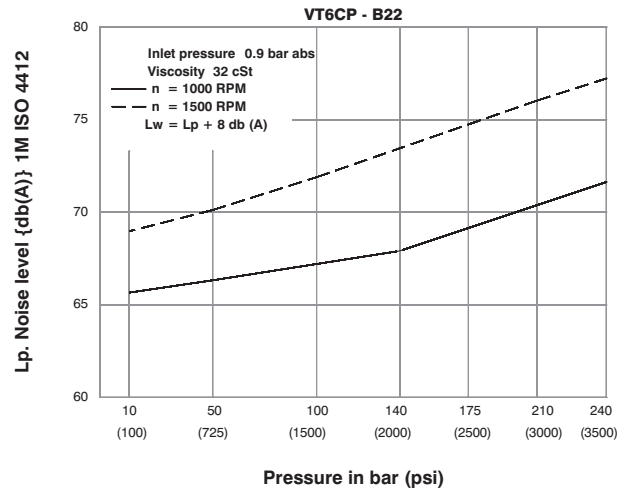

HYDROMECHANICAL POWER LOSS (TYPICAL)

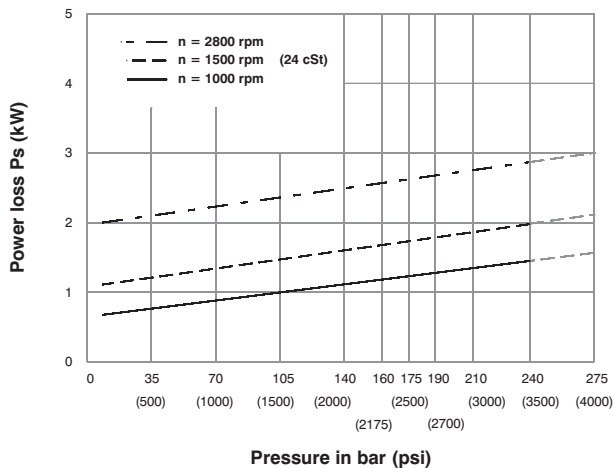

PERMISSIBLE RADIAL LOAD

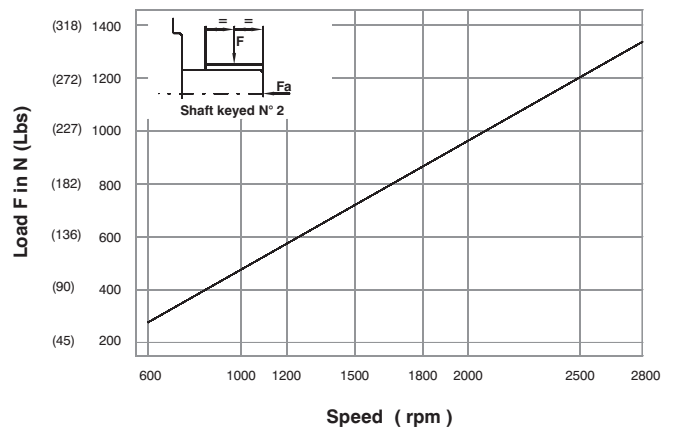

Maximum axial load permissible $F_a = 800 \text{ N}$ (180 Lbs)

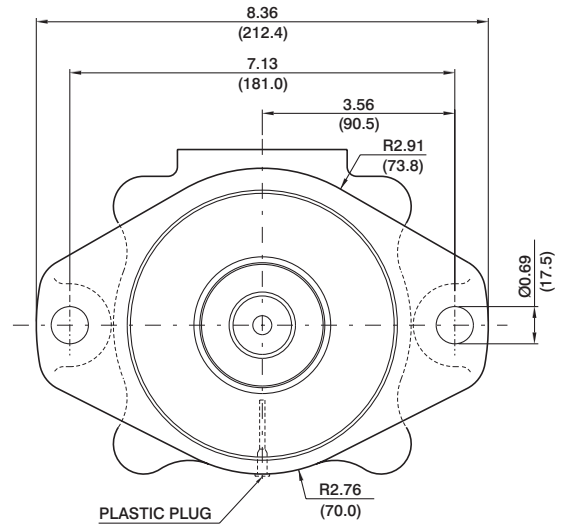
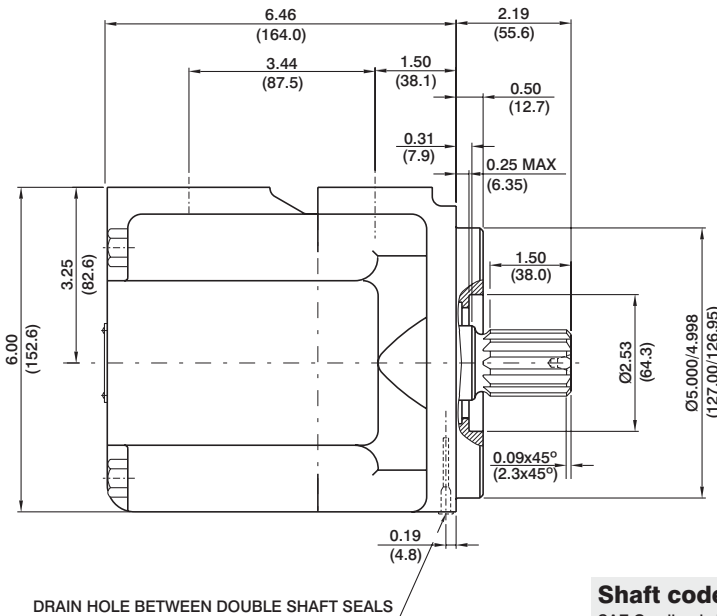
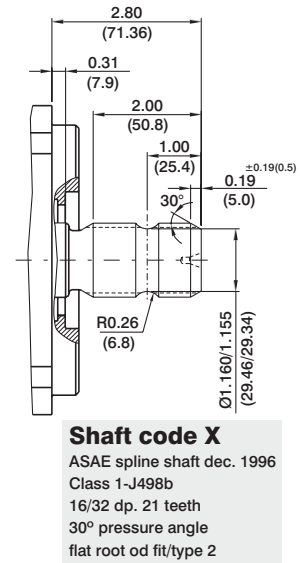
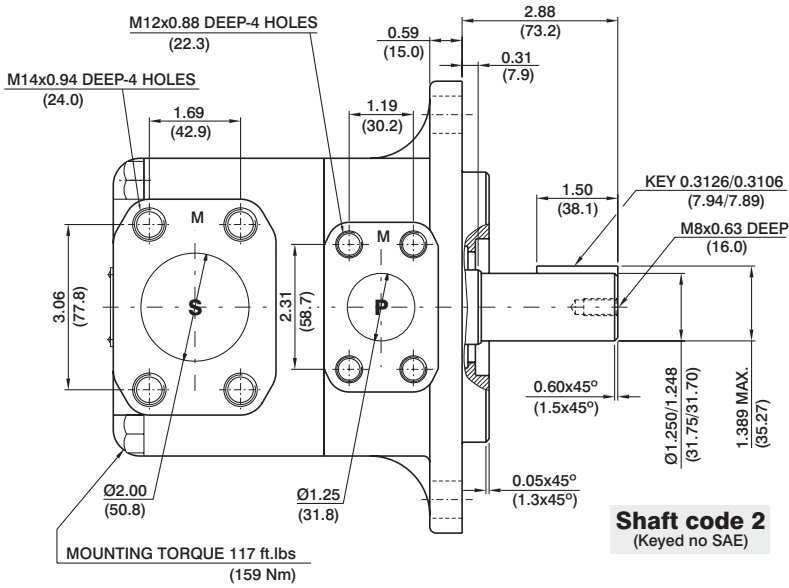

OPERATING CHARACTERISTICS - TYPICAL (24 cST)

Pressure port	Series	Volumetric Displacement Vp		Flow q & n = 1500 rpm						Input power p & n = 1500 rpm					
		in ³ /rev	cm ³ /rev	p = 0 bar (0 psi)		p = 140 bar (2000 psi)		p = 240 bar (3500 psi)		p = 7 bar (100 psi)		p = 140 bar (2000 psi)		p = 240 bar (3500 psi)	
				gpm	lpm	gpm	lpm	gpm	lpm	hp	kw	hp	kw	hp	kw
VT6CP	B14	2.81	46.0	18.25	69.0	16.79	63.5	15.60	59.0	2.55	1.9	23.60	17.6	39.56	29.5
	B15	3.08	50.5	20.00	75.6	18.62	70.4	17.46	66.0	2.68	2.0	25.61	19.1	42.91	32.0
	B17	3.56	58.3	23.12	87.4	21.69	82.0	20.50	77.5	2.82	2.1	29.37	21.9	49.48	36.9
	B20	3.89	63.8	25.32	95.7	23.86	90.2	22.67	85.7	2.95	2.2	31.92	23.8	53.91	40.2
	B22	4.29	70.3	27.88	105.4	26.45	100.0	25.26	95.5	3.08	2.3	35.00	26.1	59.14	44.1
	B25 ¹⁾	4.84	79.3	31.46	118.9	30.02	113.5	28.83	109.0	3.35	2.5	39.16	29.2	66.38	49.5
	B28 ^{1,2)}	5.42	88.8	35.24	133.2	33.78	127.7	32.93	124.5	3.75	2.8	43.85	32.7	65.04	48.5
	B31 ^{1,2)}	6.10	100.0	39.68	150.0	38.22	144.5	37.38	141.3	3.75	2.8	48.95	36.5	72.95	54.4

1) B25-B28-B31 = 2500 R.P.M. max.

2) B28-B31 = 210 bar (3000 psi) max. int.

Series VT6D * * * - B45 - 1 R 00 - C 1 *

N - Shaft seal installed reverse
Q - Special mounting cap with ear orientation of 20° from standard
M = Mobile 1 shaft seal
P = Mobile 2 shaft seal
Y - Metric port connection (not for code 'Q')
 Omit for UNC

Cam ring
 Volumetric displacement cm³/rev (in³/rev)
 * B14/R14 = 47.6 (2.90) B35/R35 = 110.0 (6.77)
 B17/R17 = 58.2 (3.55) B38/R38 = 120.3 (7.34)
 B20/R20 = 66.0 (4.03) B42/R42 = 136.0 (8.30)
 B24/R24 = 79.5 (4.85) B45/R45 = 145.7 (8.89)
 B28/R28 = 89.7 (5.47) B50/R50 = 158.0 (9.64)
 B31/R31 = 98.3 (6.00) B61/R61 = 190.5 (11.62)

*'B' - for Mobile 'R' - for Mobile - spring assisted

Type of shaft

M version **P version**
 1 - keyed (SAE C) 3 - splined (no SAE)
 2 - keyed (no SAE)
 3 - splined (SAE C)
 4 - splined (no SAE)
 T - splined (SAE J718c)

Modifications

Seal class
 1 - S1 (for mineral oil)
 4 - S4 (for fire resistant fluids)
 5 - S5 (for mineral oil and fire resistant fluids)

Design letter

Porting combination
 00 - standard

S - Suction port **P** - Pressure port

Direction of rotation (view on shaft end)
 R - clockwise
 L - counter-clockwise

INTERNAL LEAKAGE (TYPICAL)

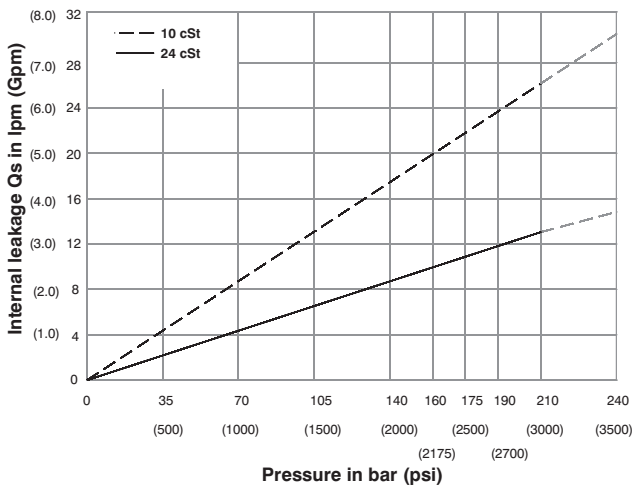

NOISE LEVEL (TYPICAL)

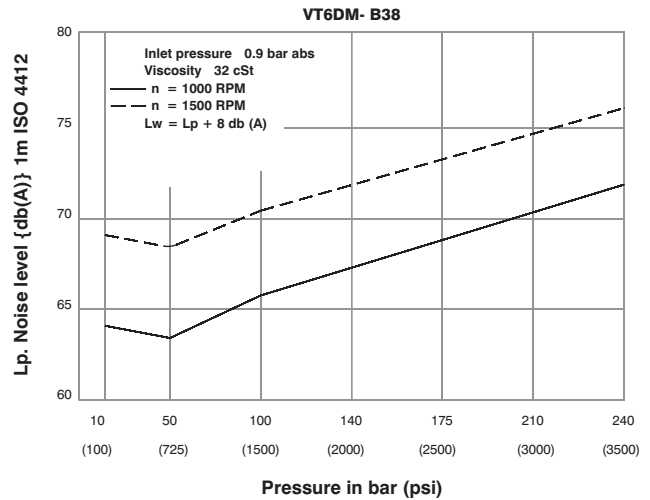

HYDROMECHANICAL POWER LOSS (TYPICAL)

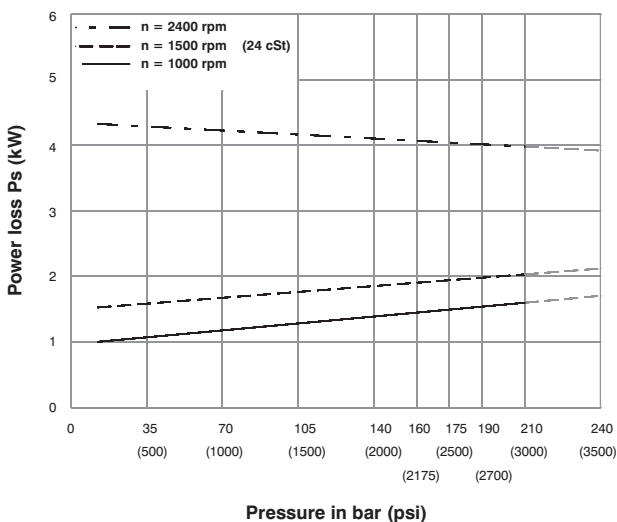

PERMISSIBLE RADIAL LOAD

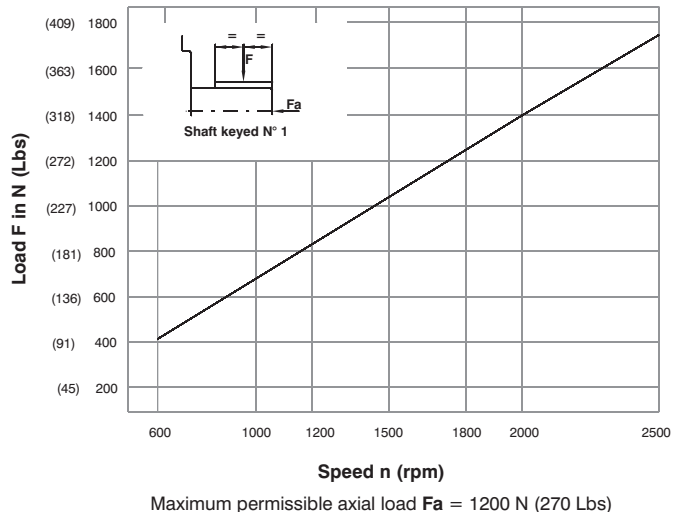

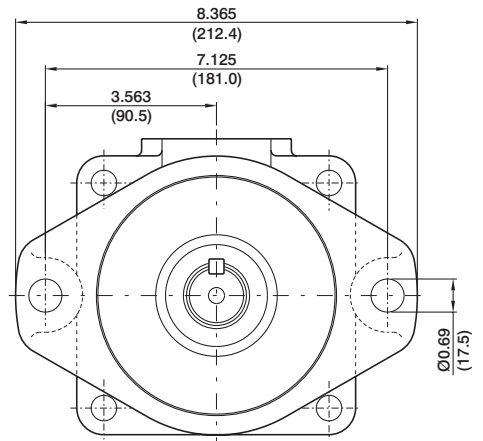
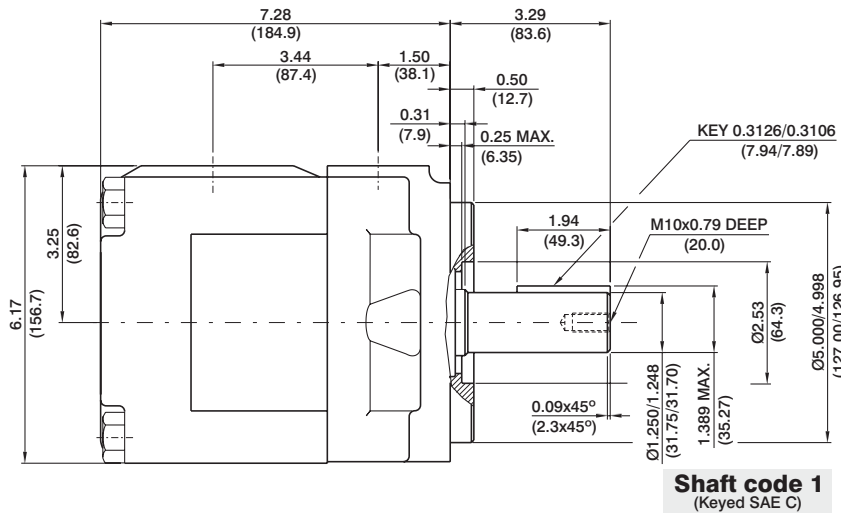
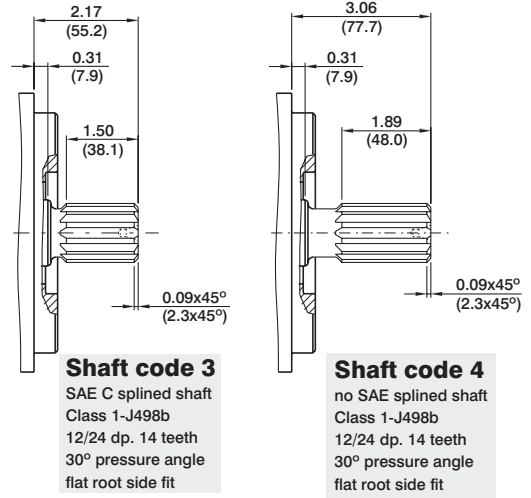
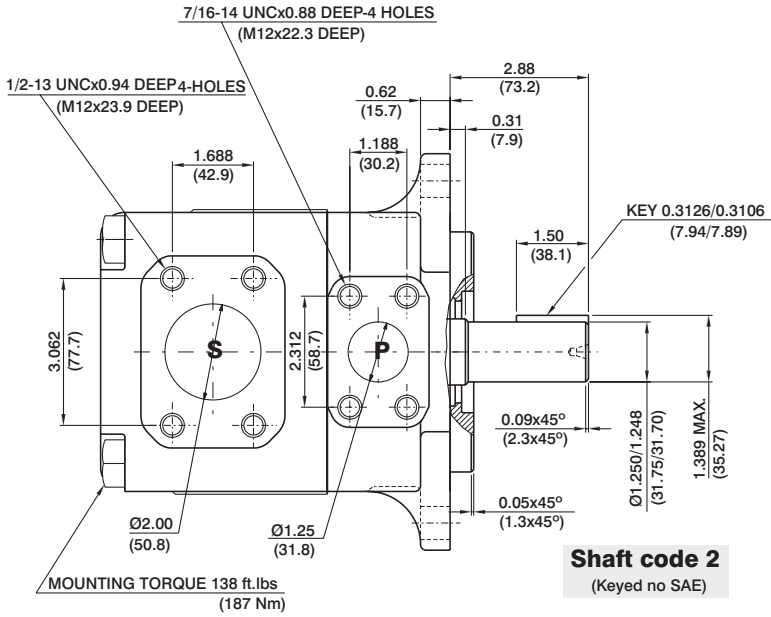

Shaft torque limits in ² /rev x psi (ml/rev x bar)	
Shaft	Vp x p max.
1	38299 (43283)
2	30638 (34590)
3	54207 (61200)
4	54207 (61200)

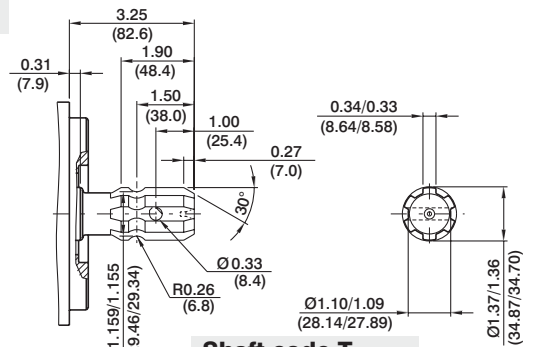
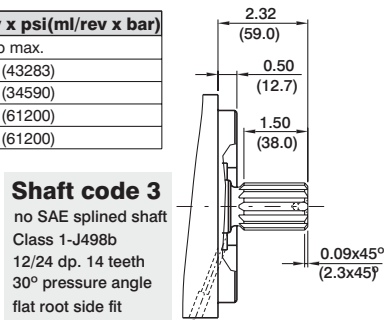

Drain hole between double shaft seals

VT6DP

OPERATING CHARACTERISTICS - TYPICAL (24 cST)

Pressure port	Series	Volumetric Displacement Vp		Flow q & n = 1500 rpm						Input power p & n = 1500 rpm					
				p = 0 bar (0 psi)		p = 140 bar (2000 psi)		p = 240 bar (3500 psi)		p = 7 bar (100 psi)		p = 140 bar (2000 psi)		p = 240 bar (3500 psi)	
		in ³ /rev	cm ³ /rev	gpm	lpm	gpm	lpm	gpm	lpm	hp	kw	hp	kw	hp	kw
VT6DM VT6DP	B14	2.90	47.6	18.88	71.4	16.42	62.1	14.78	55.9	3.08	2.3	24.81	18.5	41.03	30.6
	B17	3.55	58.2	23.1	87.3	20.6	78.0	18.99	71.8	3.35	2.5	29.77	22.2	49.62	37.0
	B20	4.00	66.0	26.19	99.0	23.73	89.7	22.08	83.5	3.75	2.8	33.39	24.9	55.92	41.7
	B24	4.80	79.5	31.56	119.3	29.10	110.0	27.46	103.8	4.02	3.0	39.69	29.6	66.78	49.8
	B28	5.50	89.7	35.58	134.5	33.12	125.2	31.48	119.0	4.29	3.2	44.52	33.2	74.96	55.9
	B31	6.00	98.3	39.00	147.5	36.53	138.1	34.89	131.9	4.42	3.3	48.54	36.2	81.80	61.0
	B35	6.80	111.0	44.04	166.5	41.58	157.2	39.94	151.0	4.69	3.5	54.58	40.7	92.13	68.7
	B38	7.30	120.3	47.72	180.4	45.26	171.1	43.62	164.9	4.96	3.7	58.87	43.9	99.64	74.3
	B42 ¹⁾	8.30	136.0	53.96	204.0	51.50	194.7	49.86	188.5	5.36	4.0	66.25	49.4	112.24	83.7
	B45 ¹⁾	8.89	145.7	57.80	218.5	55.34	209.2	53.70	203.0	5.50	4.1	70.81	52.8	120.02	89.5
	B50 ^{1,2)}	9.64	158.0	62.69	237.0	60.23	227.7	59.25	224.0	5.90	4.4	76.44	57.0	113.98	85.0
	B61 ^{1,3)}	11.62	190.5	76.25	285.7	73.54	278.0	--	--	6.16	4.6	81.26	60.6	--	--

1) B42-B45-B50-B61=2200 RPM max.

2) B50=210 bar (3000 psi) max. int.

3) 061 = 120 bar (1740 psi) max. int.

061 = 80 bar (1160 psi) cont.

Series **VT6E** * * - **066** - **3** **R** **00** - **B** **1** *

M= Mobile 1 shaft seal
P= Mobile 2 shaft seal
Y - Metric port connection, Omit for UNC

Cam ring
 Volumetric displacement cm³/rev (in³/rev)

* 042/R42	= 132.3 (8.07)
045/R45	= 142.4 (8.69)
050/R50	= 158.5 (9.67)
052/R52	= 164.8 (10.06)
057/R57	= 180.7 (11.02)
062/R62	= 196.7 (12.00)
066/R66	= 213.3 (13.02)
072/R72	= 227.1 (13.86)
085/R85	= 269.8 (16.46)

'R' - for Mobile - spring assisted

Type of shaft

M version	P version
1 - keyed (SAE CC)	3 - splined (no SAE)
2 - keyed (no SAE)	
3 - splined (SAE C)	
4 - splined (SAE CC)	
T - splined (SAE J718c)	

Modifications

Seal class

- 1 - S1 (for mineral oil)
- 4 - S4 (for fire resistant fluids)
- 5 - S5 (for mineral oil and fire resistant fluids)

Design letter

Porting combination

00 - standard

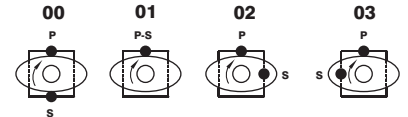

S - Suction port P - Pressure port

Direction of rotation (view on shaft end)

- R - clockwise
- L - counter-clockwise

INTERNAL LEAKAGE (TYPICAL)

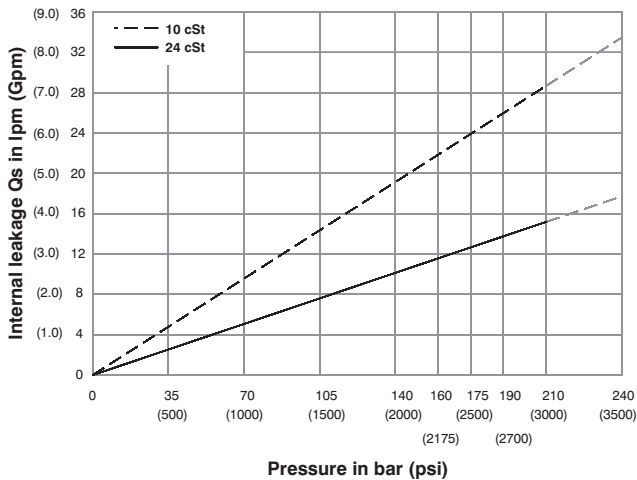

NOISE LEVEL (TYPICAL)

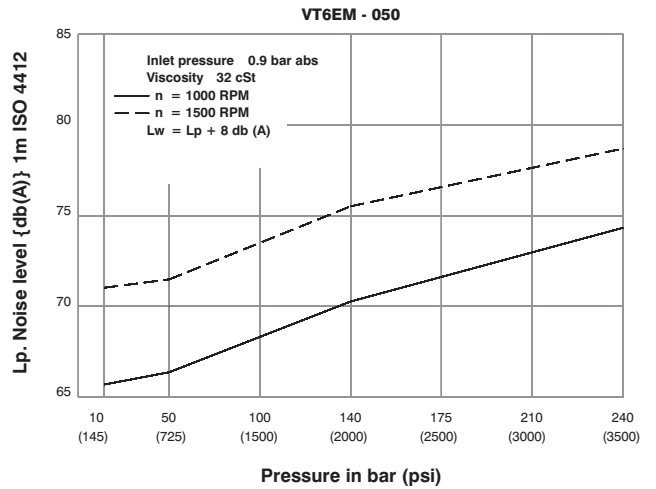

HYDROMECHANICAL POWER LOSS (TYPICAL)

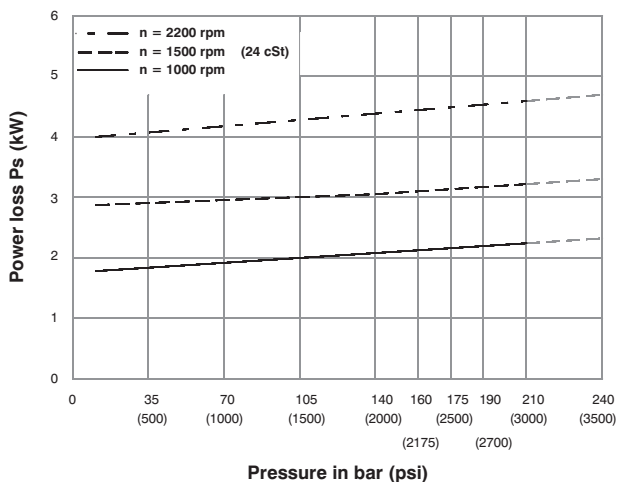

PERMISSIBLE RADIAL LOAD

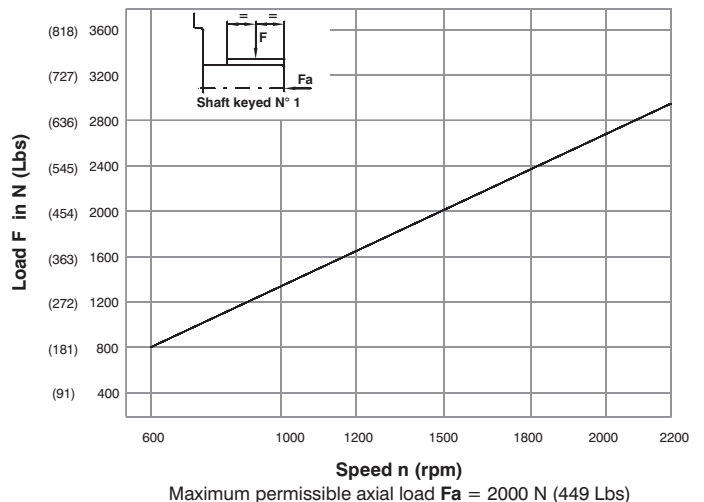

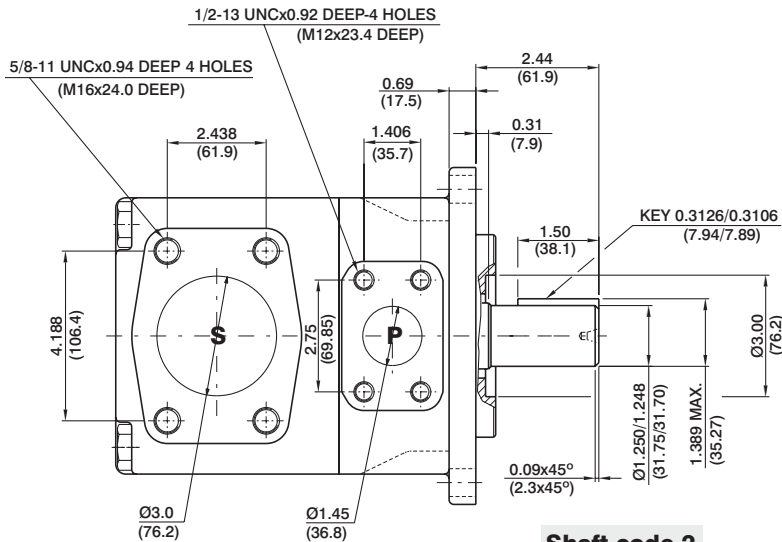

Shaft code 2
(keyed no SAE)

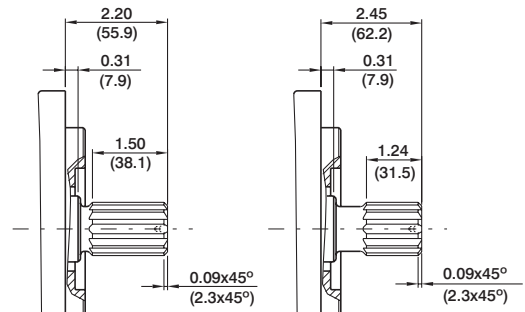

Shaft code 3
SAE C splined shaft
Class 1-J498b
12/24 dp. 14 teeth
30° pressure angle
flat root side fit

Shaft code 4
SAE CC splined shaft
Class 1-J498b
12/24 dp. 17 teeth
30° pressure angle
flat root side fit

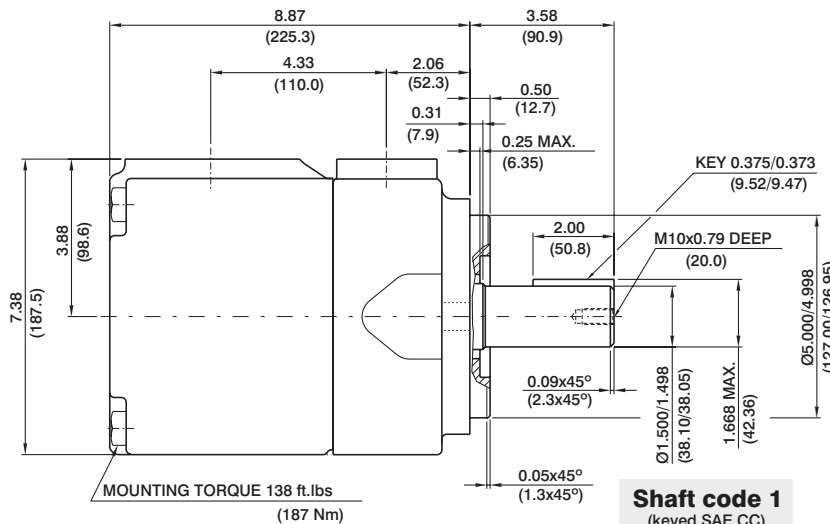

Shaft code 1
(keyed SAE CC)

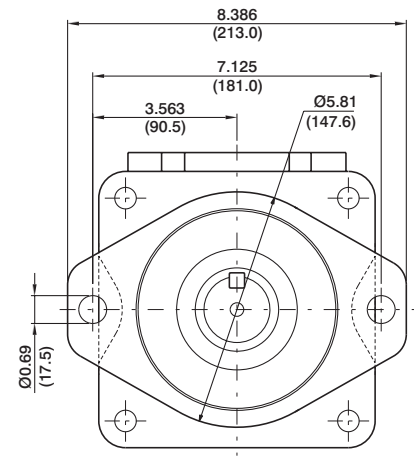

Shaft torque limits in ³ /rev x psi (ml/rev x bar)	
Shaft	Vp x p max.
1	48273 (54555)
2	30638 (34590)
3	54207 (61200)
4	54207 (61200)
T	62356 (70400)

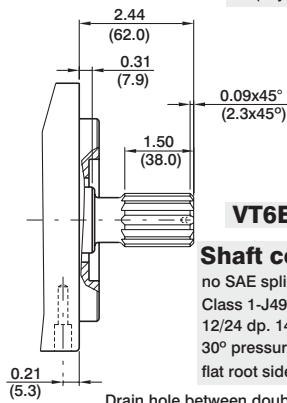

Shaft code 3
no SAE splined shaft
Class 1-J498b
12/24 dp. 14 teeth
30° pressure angle
flat root side fit

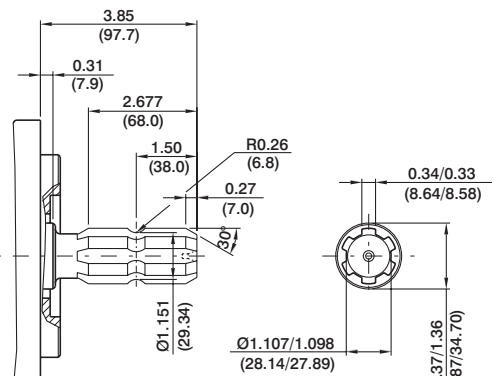

Shaft code T
SAE J718C
540 rpm power take-off
For Farm Tractor application

Drain hole between double Shaft seals

OPERATING CHARACTERISTICS - TYPICAL (24 cST)

Pressure port	Series	Volumetric Displacement Vp		Flow q & n = 1500 rpm						Input power p & n = 1500 rpm					
				p = 0 bar (0 psi)		p = 140 bar (2000 psi)		p = 240 bar (3500 psi)		p = 7 bar (100 psi)		p = 140 bar (2000 psi)		p = 240 bar (3500 psi)	
		in ³ /rev	cm ³ /rev	gpm	lpm	gpm	lpm	gpm	lpm	hp	kw	hp	kw	hp	kw
VT6EM VT6EP	042	8.07	132.3	52.50	198.5	49.87	188.5	47.96	181.3	6.97	5.2	66.25	49.4	110.77	82.6
	045	8.70	142.4	56.51	213.6	53.86	203.6	51.98	196.5	7.24	5.4	70.94	52.9	118.95	88.7
	050	9.67	158.5	62.88	237.7	60.24	227.7	58.36	220.6	7.64	5.7	78.45	58.5	131.82	98.3
	052	10.00	164.8	65.40	247.2	62.75	237.2	60.87	230.1	7.78	5.8	81.53	60.8	136.92	102.1
	057	11.02	180.7	71.71	271.1	69.07	261.1	67.19	254.0	8.18	6.1	89.04	66.4	143.35	106.9
	062	12.00	196.7	78.04	295.0	75.40	285.0	73.52	277.9	8.58	6.4	96.42	71.9	162.67	121.3
	066	13.00	213.3	84.63	319.9	81.98	309.9	80.11	302.8	8.98	6.7	104.20	77.7	175.94	131.2
	072	13.86	227.1	90.11	340.6	87.46	330.6	85.58	323.5	9.25	6.9	110.77	82.6	187.07	139.5
	085 ^{1,2)}	16.40	269.8	107.00	404.7	105.21	397.7	--	--	9.78	7.3	87.56	65.3	--	--

1) 085 = 2000 RPM max.

2) 085 = 75 bar (1100 psi) cont.

085 = 90 bar (1300 psi) max. int.



VT7B or VT7BS - B10 - 1 R 00 - A 1 M0 -

Series

VT7B series-100 A2 HW
ISO 2 bolts \varnothing 019-2 mounting flange
VT7BS series- SAE B 2 bolts
Mounting flange J744

Camring

Volumetric displacement cm^3/rev (in^3/rev)

B02 = 5.7 (0.35)	B09 = 28.0 (1.71)
B03 = 9.8 (0.60)	B10 = \varnothing 1.8 (1.94)
B04 = 12.8 (0.78)	B11 = \varnothing 4.9 (2.1 \varnothing)
B05 = 15.9 (0.97)	B12 = 40.9 (2.50)
B06 = 19.8 (1.21)	B14 = 45.1 (2.75)
B07 = 22.5 (1.37)	B15 = 50.0 (\varnothing .05)
B08 = 24.9 (1.52)	

Type of shaft VT7B-VT7BS

2 - Keyed (ISO R775)

Type of shaft VT7BS

1 - Keyed (SAE B)
 \varnothing - Splined (SAE B)
4 - Splined (SAE BB)

Direction of rotation (view on shaft end)

R - clockwise
L - counter-clockwise

Modifications

Mounting W/connection variables

4 bolts SAE flange (J518C)

	UNC VT7BS		METRIC VT7B-VT7BS	
	00	01	M0	M1
P	1"	\varnothing 3/4"	1"	\varnothing 3/4"
S	1 1/2"			

Seal class

1 - S1 (for mineral oil)
4 - S4 (for fire resistant fluids)
5 - S5 (for mineral oil and fire resistant fluids)

Design letter

Porting combination

00 - standard

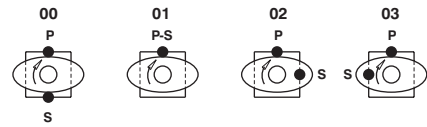

S - Suction port P - Pressure port

INTERNAL LEAKAGE (TYPICAL)

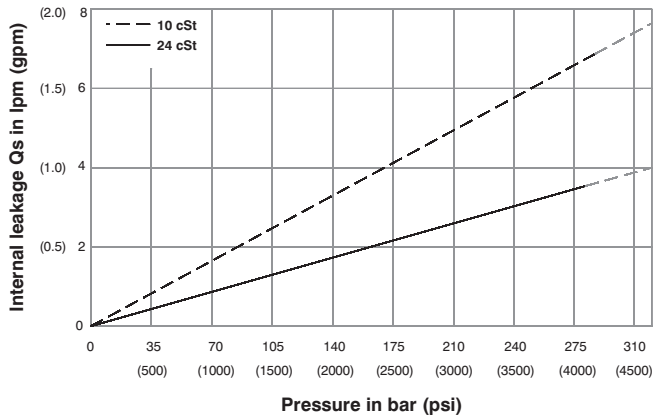

NOISE LEVEL (TYPICAL)

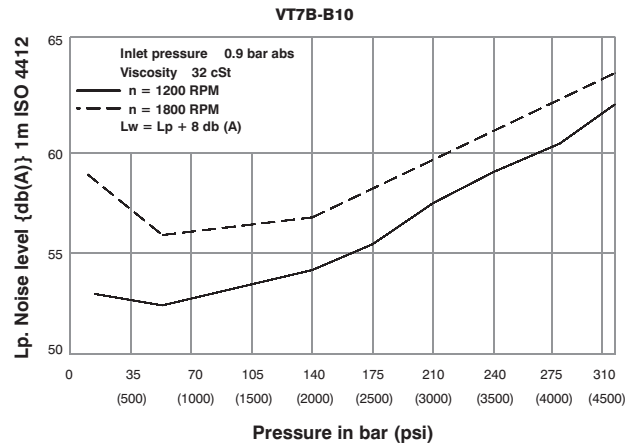

HYDROMECHANICAL POWER LOSS (TYPICAL)

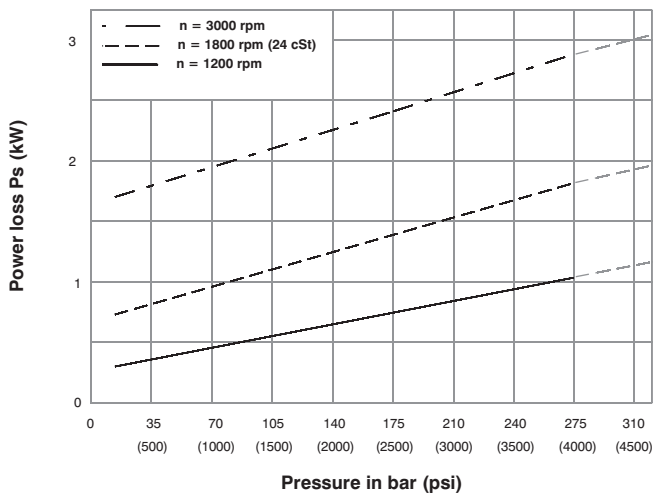

PERMISSIBLE RADIAL LOAD

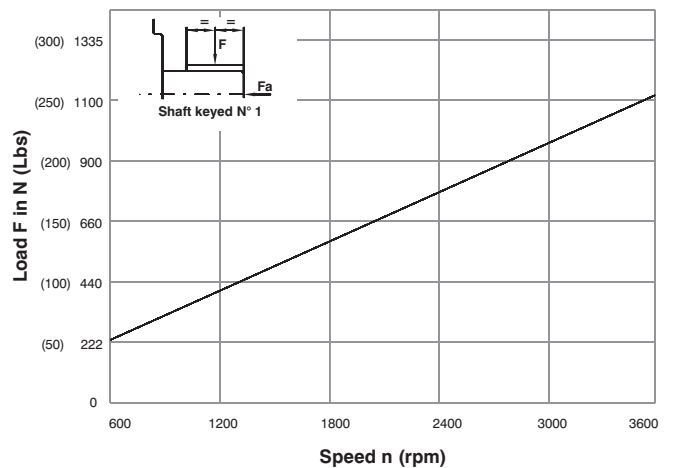

Maximum axial load permissible $F_a = 800 \text{ N (180 Lbs)}$

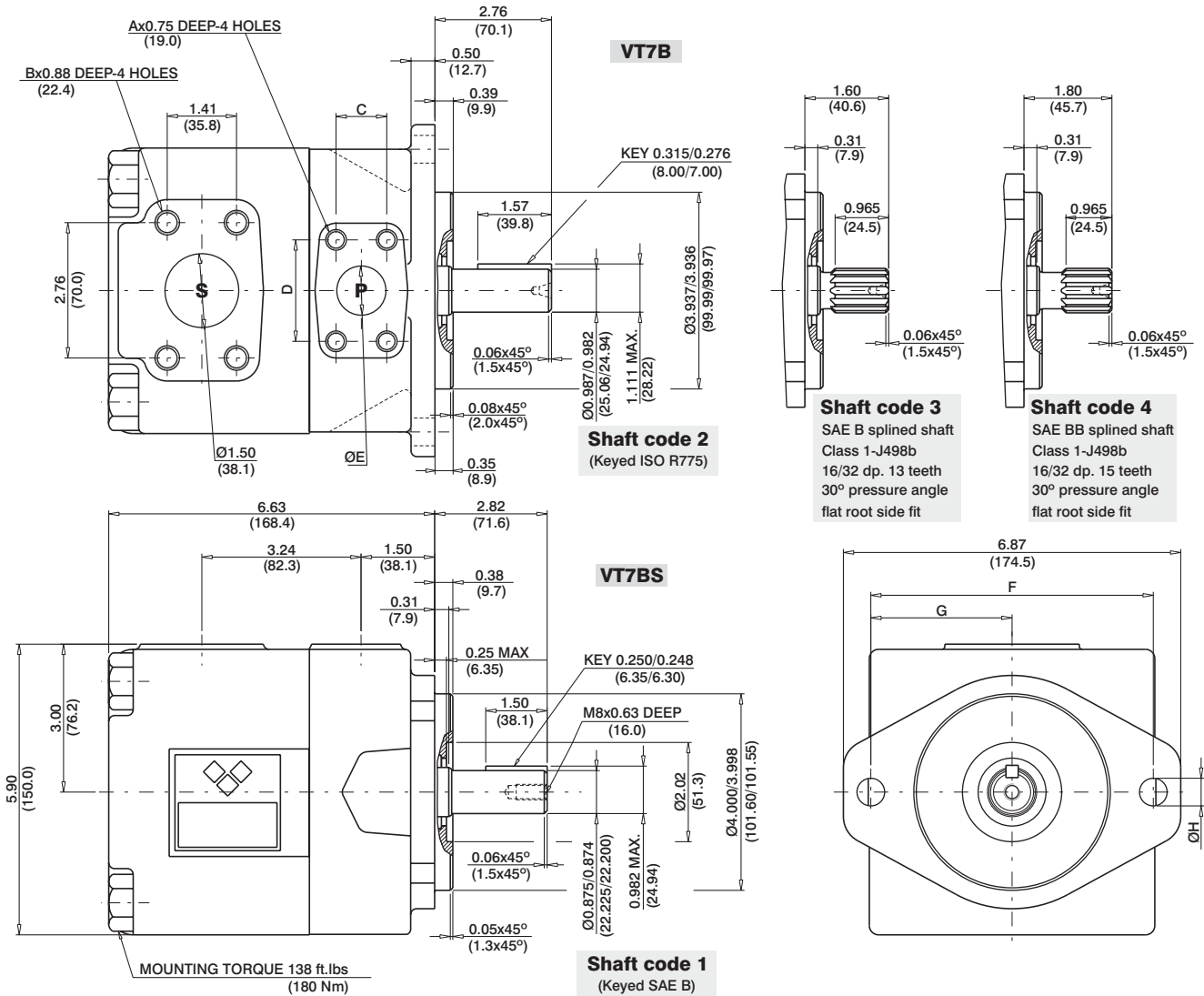

	VT7BS		VT7B	
	00	01	M0	M1
A	3/8-16 UNC		M10	
B	1/2-13 UNC		M12	
C	1.03 (26.2)	0.874 (22.2)	1.03 (26.2)	0.874 (22.2)
D	2.06 (52.4)	1.874 (47.6)	2.06 (52.4)	1.874 (47.6)
ØE	1.00 (25.4)	0.75 (19.05)	1.00 (25.4)	0.75 (19.05)
F	5.75 (146.0)		5.51 (140.0)	
G	2.87 (73.0)		2.75 (70.0)	
ØH	0.56 (14.3)		0.55 (14.0)	

Shaft torque limits in ³ /rev x psi (ml/rev x bar)	
Shaft	Vp x p max.
1	14615 (16516)
2	18246 (20620)
3	18246 (20620)
4	18246 (20620)

OPERATING CHARACTERISTICS - TYPICAL (24 cST)

Pressure port	Series	Volumetric Displacement Vp		Flow q & n = 1800 rpm						Input power p & n = 1800 rpm					
		p = 0 bar (0 psi)		p = 140 bar (2000 psi)		p = 320 bar (4650 psi)		p = 7 bar (100 psi)		p = 140 bar (2000 psi)		p = 320 bar (4650 psi)			
		in ³ /rev	cm ³ /rev	gpm	lpm	gpm	lpm	gpm	lpm	hp	kw	hp	kw	hp	kw
VT7B VT7BS	B02	0.35	5.7	2.76	10.4	2.33	8.8	1.73	6.5	0.74	0.55	4.02	2.99	8.59	6.40
	B03	0.60	9.8	4.66	17.6	4.23	15.9	3.70	13.7	0.85	0.63	6.24	4.65	13.75	10.25
	B04	0.78	12.8	6.09	23.0	5.66	21.4	5.06	19.2	0.94	0.70	7.90	5.89	17.62	13.13
	B05	0.97	15.9	7.56	28.6	7.13	26.9	6.53	24.7	1.02	0.76	9.62	7.17	21.62	16.12
	B06	1.21	19.8	9.42	35.6	8.99	33.9	8.39	31.7	1.13	0.84	11.79	8.79	26.66	19.88
	B07	1.37	22.5	10.70	40.4	10.27	38.8	9.67	36.5	1.20	0.89	13.29	9.91	30.14	22.47
	B08	1.52	24.9	11.84	44.7	11.41	43.1	10.81	40.9	1.27	0.94	14.62	10.90	33.24	24.78
	B09	1.71	28.0	13.31	50.3	12.87	48.6	12.28	46.4	1.36	1.01	16.35	12.19	37.25	27.77
	B10	1.94	31.8	15.12	57.2	14.69	55.5	14.09	53.4	1.46	1.11	18.45	13.75	42.14	31.42
	B11 ¹⁾	2.13	34.9	16.64	62.9	16.19	61.2	15.61	59.0	1.55	1.15	20.17	15.04	43.22	32.22
	B12 ¹⁾	2.50	40.9	19.50	73.7	19.07	72.1	18.54	70.1	1.72	1.28	23.55	17.56	50.58	37.71
	B14 ¹⁾	2.75	45.1	21.40	80.8	20.95	79.2	20.37	77.0	1.83	1.36	25.80	19.23	55.48	41.37
	B15 ¹⁾	3.05	50.0	23.78	89.8	23.35	88.3	22.88	86.5	1.97	1.47	28.55	21.28	57.35	42.76

1) B11-B12-B14 = 300 bar (4350 psi) & B15 = 280 bar (4060 psi) max. int. And Max. Speed = 3000 rpm



VT7QC 1 - 022 - 1 R 00 - B 1 - 00 *

Series

Mounting

- 1 - SAE B
- 2 - SAE C

Camring

(Delivery @ 0 bar & 1500 rpm)

*00 ³ /B0 ³ /Y0 ³ = 16.2 l/min	015/B15/Y15 = 75.1 l/min
005/B05/Y05 = 25.8 l/min	017/B17/Y17 = 87.4 l/min
006/B06/Y06 = ³ 1.9 l/min	020/B20/Y20 = 95.7 l/min
008/B08/Y08 = ³ 9.6 l/min	022/B22/Y22 = 105.4 l/min
010/B10/Y10 = 51.1 l/min	025/B25/Y25 = 118.9 l/min
012/B12/Y12 = 55.6 l/min	028/B28/Y28 = 1 ³ .2 l/min
014/B14/Y14 = 69.0 l/min	0 ³ 1/B ³ 1/Y ³ 1 = 150.0 l/min

*'0' - Uni - directional 'B' - Bi - directional 'Y' - Bi - directional for cold start

Type of shaft

- 1 - Keyed (SAE B)
- 2 - Keyed (non SAE)
- ³ - Splined (SAE B)
- 4 - Splined (SAE BB)

Modifications

Mounting W/connection variables

	UNC		METRIC	
	00	01	M0	M1
P	1"	³ / ₄ "	1"	³ / ₄ "
S	1 1/2"			

Seal class

- 1 - S1 (for mineral oil)
- 4 - S4 (for fire resistant fluids)
- 5 - S5 (for mineral oil and fire resistant fluids)

Design letter

Porting combination

00 - standard

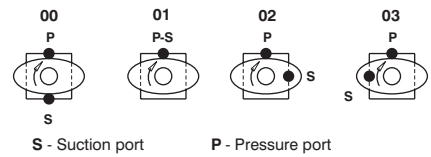

Direction of rotation (view on shaft end)

- R - clockwise
- L - counter-clockwise

INTERNAL LEAKAGE (TYPICAL)

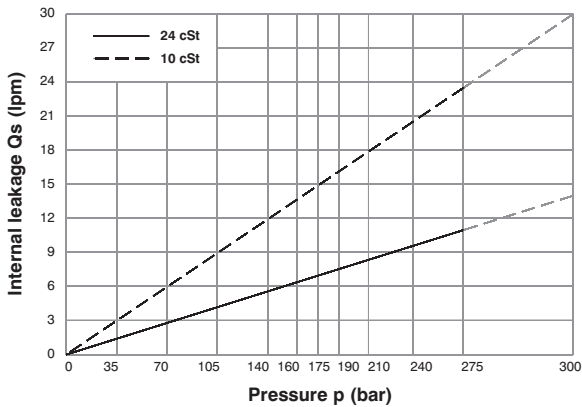

Do not operate pump more than 5 seconds at any speed or viscosity if internal leakage is more than 50% of theoretical flow.

NOISE LEVEL (TYPICAL)

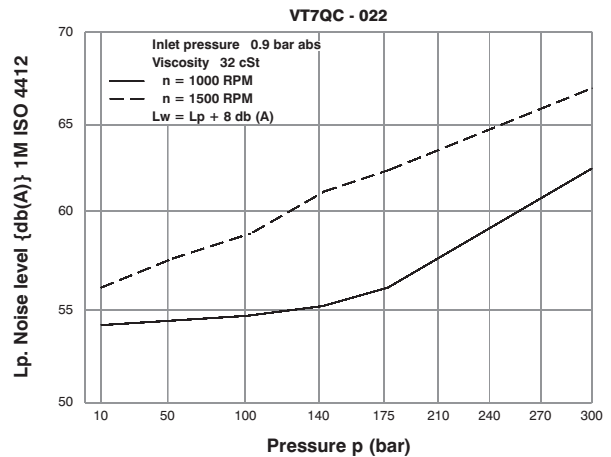

HYDROMECHANICAL POWER LOSS (TYPICAL)

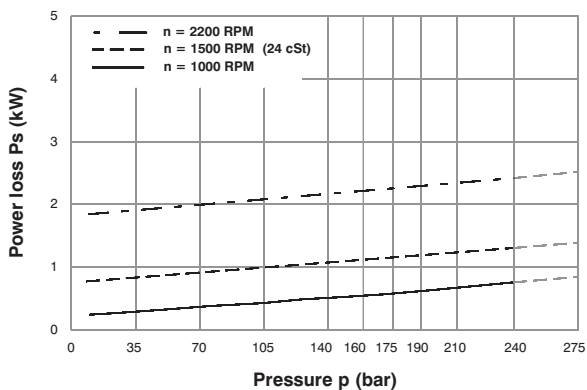

PERMISSIBLE RADIAL LOAD

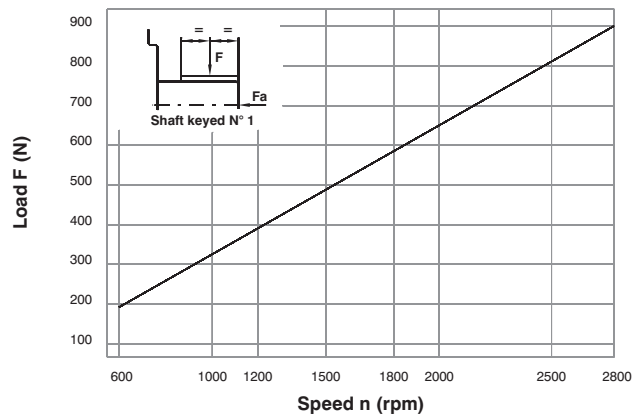

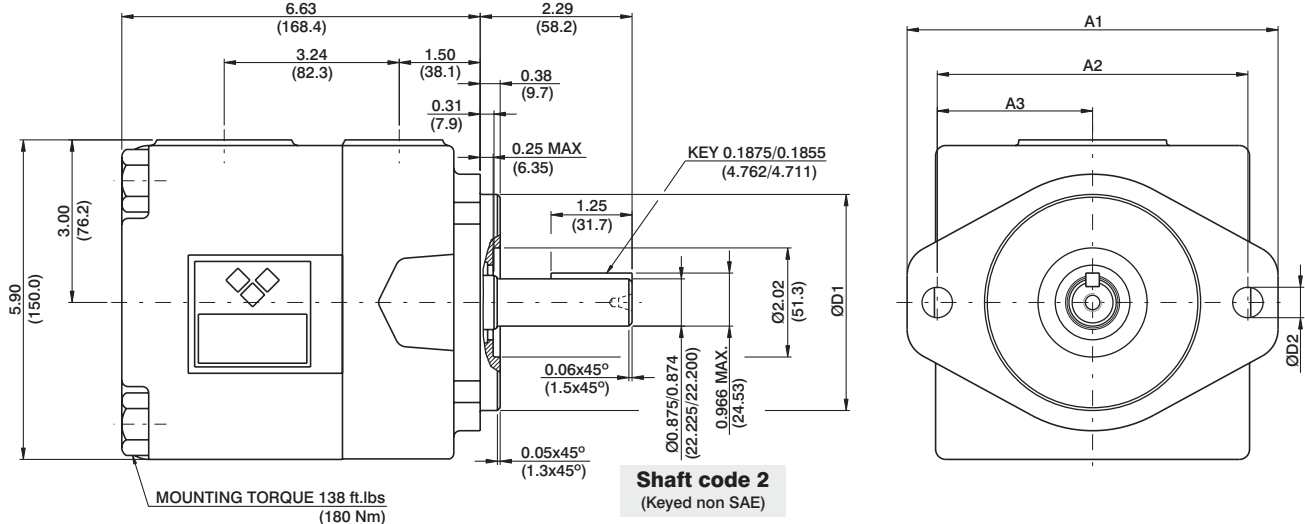
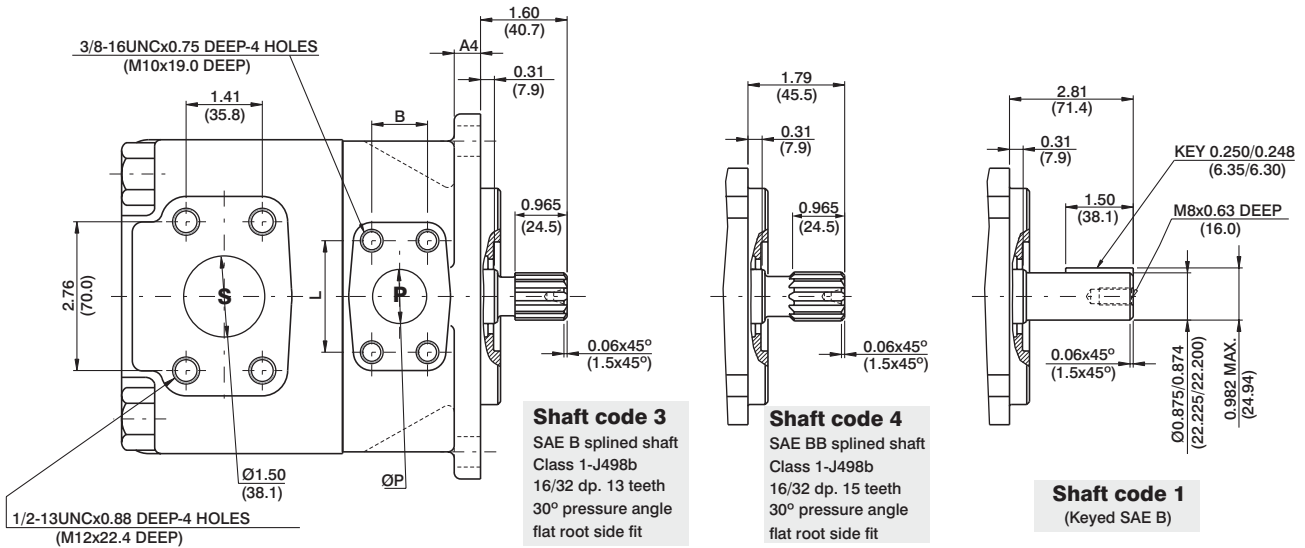

	VT7QC1	VT7QC2
Mounting	SAE B	SAE C
ØD1	4.000 (101.60) 3.998 (101.55)	5.000 (127.00) 4.997 (126.94)
ØD2	0.56 (14.3)	0.69 (17.5)
A1	6.87 (174.5)	8.36 (212.5)
A2	5.75 (146.0)	7.13 (181.0)
A3	2.87 (73.0)	3.56 (90.5)
A4	0.5 (12.7)	0.62 (15.7)

ØP	L	B
0.75 (19.05)	1.874 (47.6)	0.874 (22.2)
1.00 (25.4)	2.06 (52.4)	1.03 (26.2)

Shaft torque limits in ³ /rev x psi (ml/rev x bar)	
Shaft	Vp x p max.
1	14473 (16500)
2	12666 (14300)
3	18246 (20600)
4	19309 (21820)

OPERATING CHARACTERISTICS - TYPICAL (24 cST)

Series	Volumetric Displacement Vp	Flow q (lpm) & n = 1500 rpm				Input power p (kW) & n = 1500 rpm			
		p = 0 bar	p = 140 bar	p = 240 bar	p = 300 bar	p = 7 bar	p = 140 bar	p = 240 bar	p = 300 bar
003	10.8 ml/rev	16.2	11.9	8.1	--	1.3	5.3	7.8	--
005	17.2 ml/rev	25.8	21.5	17.7	13.7	1.4	7.5	12.2	14.9
006	21.3 ml/rev	31.9	26.5	22.0	18.0	1.5	8.9	14.7	18.0
008	26.4 ml/rev	39.6	34.1	29.6	25.6	1.6	10.7	17.7	21.8
010	34.1 ml/rev	51.1	45.7	41.2	37.2	1.7	13.4	22.3	27.5
012	37.1 ml/rev	55.6	50.2	45.7	41.7	1.7	14.4	24.1	29.8
014	46.0 ml/rev	69.0	63.5	59.0	55.0	1.9	17.6	29.5	36.5
015	50.5 ml/rev	75.1	69.6	65.1	61.1	2.0	18.0	32.0	39.5
017	58.3 ml/rev	87.4	82.0	77.5	73.5	2.1	19.0	36.9	45.7
020	63.8 ml/rev	95.7	90.2	85.7	81.7	2.2	23.8	40.2	49.8
022 ²⁾	70.3 ml/rev	105.4	100.0	95.5	91.5	2.3	26.1	44.1	50.3
025 ^{1,3)}	79.3 ml/rev	118.9	113.5	109.0	--	2.5	29.2	49.5	--
028 ^{1,4)}	88.8 ml/rev	133.2	127.7	124.5	--	2.8	32.7	48.5	--
031 ^{1,4)}	100.0 ml/rev	150.0	144.5	141.3	--	2.8	36.5	54.4	--

1) 025-028-031 = 2500 R.P.M. max. 2) 022 = 275 bar max. int. 3) 025 = 240 bar max. int. 4) 028-031 = 210 bar max. int.
-- Not to use because internal leakage greater than 50% of theoretical flow.



VT7D or VT7DS - B42 - 1 R 00 - A 1 M0 -

Series

VT7D series-125 A2 HW
ISO 2 bolts ³ 019-2 mounting flange
VT7DS series- SAE C 2 bolts
Mounting flange J744

Camring

Volumetric displacement cm³/rev (in³/rev)
 B14 = 4³.9 (2.68) B³ 1 = 99.1 (6.05)
 B17 = 55.0 (3.36) B³ 5 = 113.4 (6.92)
 B20 = 66.0 (4.03) B³ 8 = 120.6 (7.36)
 B22 = 70.3 (4.29) B42 = 137.5 (8.39)
 B24 = 81.1 (4.95) 045 = 145.7 (8.89)
 B28 = 89.9 (5.49) 050 = 157.9 (9.64)

Type of shaft VT7DS

1 - keyed (SAE C ³ 2-1)
 2 - keyed (no SAE)
³ - splined (SAE C ³ 2-4)
 4 - splined (no SAE)

Type of shaft VT7D - VT7DS

5 - keyed (ISO ³ 019-2-G³ 2M)

Direction of rotation (view on shaft end)

R - clockwise
 L - counter-clockwise

Modifications

Mounting w/connection variables

4 bolts SAE flange J518

P = 1-1/4"		S = 2"	
	UNC	METRIC	
VT7D		M0	
VT7DS	00	M0	Y0 ¹⁾

1) 250 bar (3630 psi) max. int.

Seal class

1 - S1 (for mineral oil)
 4 - S4 (for fire resistant fluids)
 5 - S5 (for mineral oil and fire resistant fluids)

Design letter

Porting combination

00 - standard

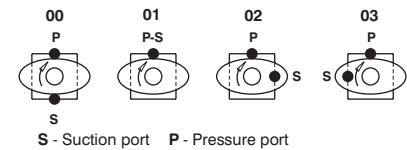

INTERNAL LEAKAGE (TYPICAL)

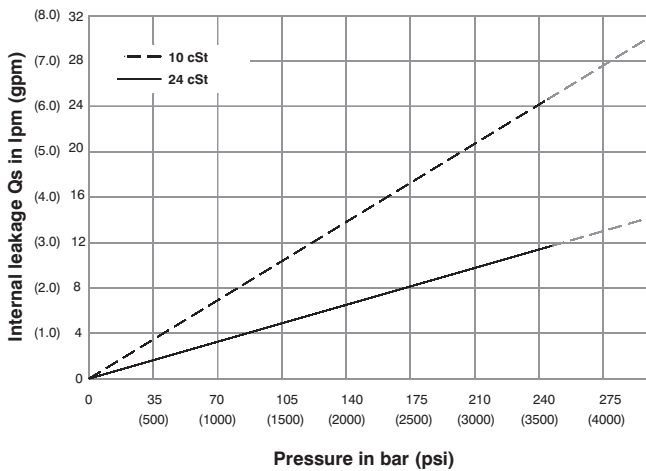

NOISE LEVEL (TYPICAL)

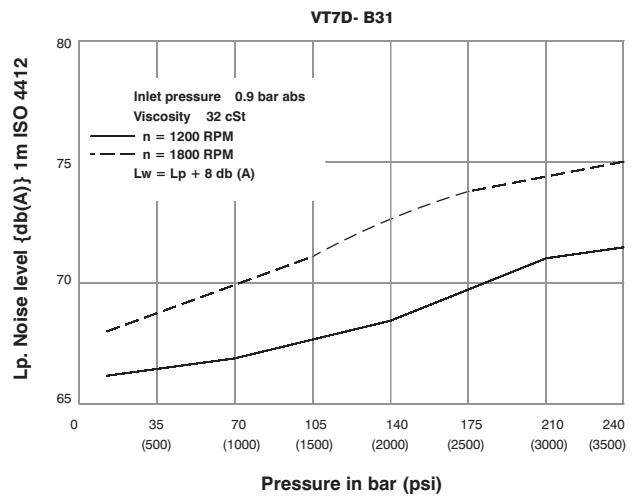

HYDROMECHANICAL POWER LOSS (TYPICAL)

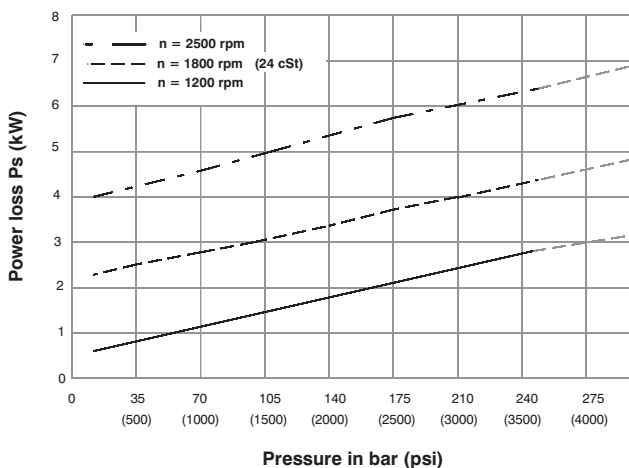

PERMISSIBLE RADIAL LOAD

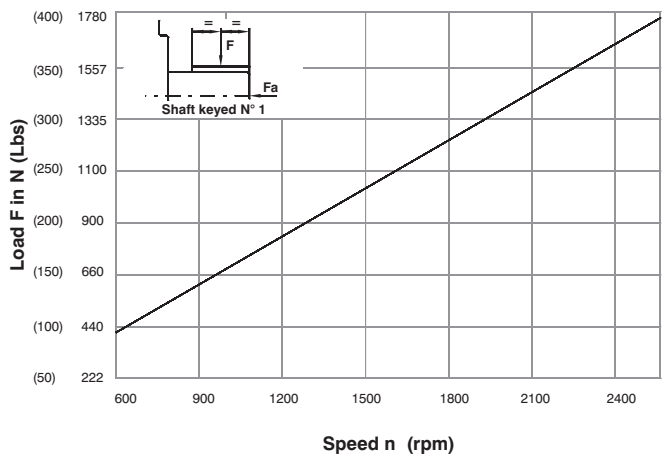

Maximum axial load permissible Fa = 1200 N (270 Lbs)

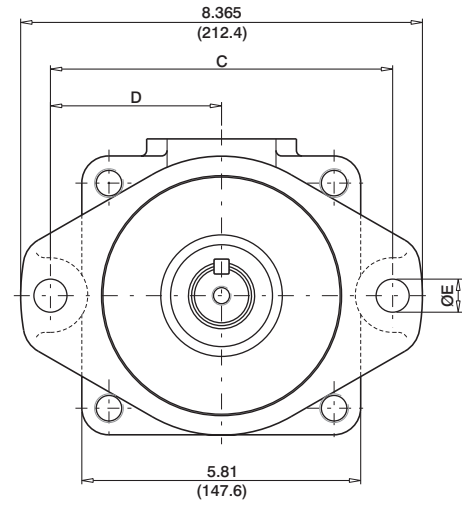
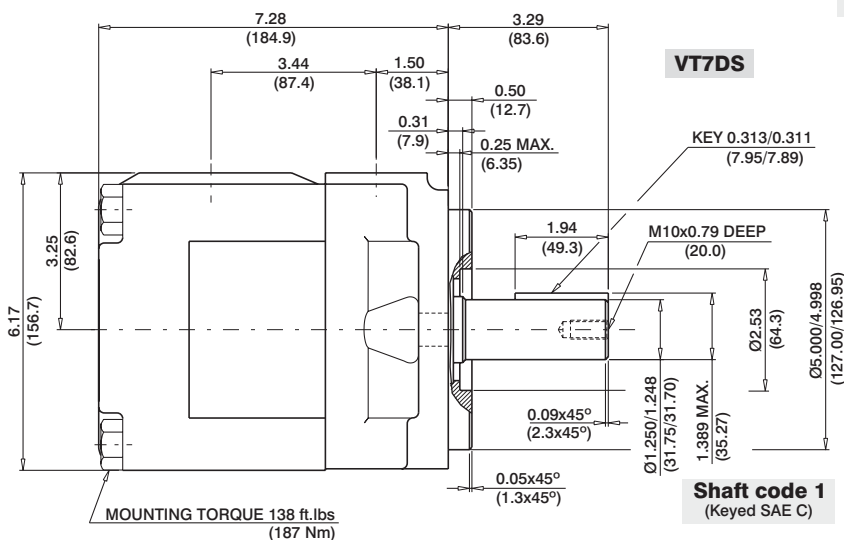
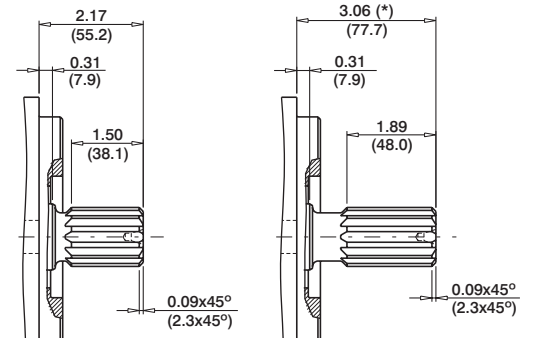
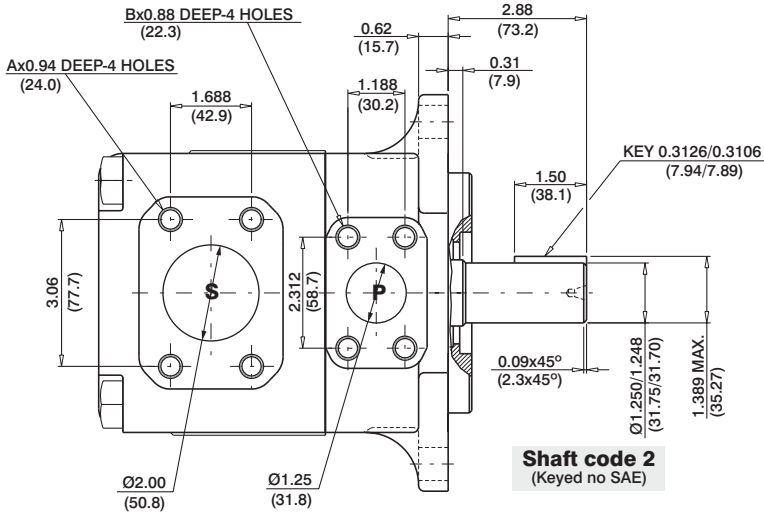

Shaft torque limits in ³ /rev x psi (ml/rev x bar)	
Shaft	Vp x p max.
1	38299 (43283)
2	30638 (34590)
3	54207 (61200)
4	54207 (61200)
5	39238 (44344)

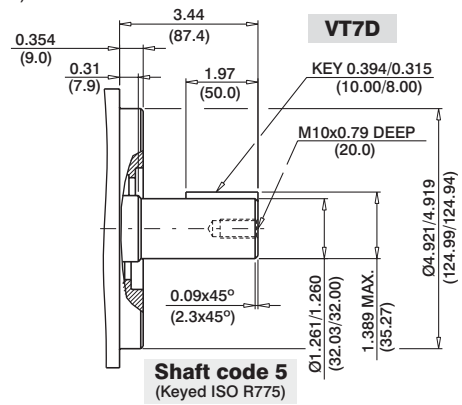

	VT7DS		VT7D	
	00	M0	Y0 ¹⁾	M0
A	1/2-13 UNC	M12	M12	M12
B	7/16-14 UNC	M12	M10	M12
C	7.12 (181.0)		7.09 (180.0)	
D	3.56 (90.5)		3.54 (90.0)	
E	0.69 (17.5)		0.71 (18.0)	

1) 250 bar (3630 psi) max.int

OPERATING CHARACTERISTICS - TYPICAL (24 cST)

Pressure port	Series	Volumetric Displacement Vp		Flow q & n = 1800 rpm						Input power p & n = 1800 rpm					
		in ³ /rev	cm ³ /rev	p = 0 bar (0 psi)		p = 140 bar (2000 psi)		p = 300 bar (4350 psi)		p = 7 bar (100 psi)		p = 140 bar (2000 psi)		p = 300 bar (4350 psi)	
				gpm	lpm	gpm	lpm	gpm	lpm	hp	kw	hp	kw	hp	kw
VT7D VT7DS	B14	2.68	43.9	20.92	79.1	19.18	72.5	17.19	64.9	3.46	2.6	27.77	20.7	58.49	43.6
	B17	3.36	55.0	26.16	98.8	24.41	92.3	22.42	84.7	3.77	2.8	33.88	25.3	71.92	53.6
	B20	4.03	66.0	31.39	118.6	29.64	112.0	27.65	104.5	4.07	3.0	39.98	29.8	85.35	63.6
	B22	4.29	70.3	33.43	126.4	31.69	119.8	29.70	112.3	4.19	3.1	42.37	31.6	90.60	67.6
	B24	4.95	81.1	38.57	145.8	36.82	139.2	34.83	131.6	4.49	3.4	48.36	36.1	103.78	77.4
	B28	5.49	89.9	42.80	161.8	41.06	155.2	39.06	147.6	4.74	3.5	53.30	39.7	114.65	85.5
	B31	6.05	99.1	47.18	178.3	45.43	171.7	43.44	164.2	4.99	3.7	58.41	43.6	125.88	93.7
	B35 ¹⁾	6.92	113.4	53.93	203.9	52.18	197.2	50.44	190.6	5.39	4.0	66.29	49.4	130.39	97.2
	B38 ¹⁾	7.36	120.6	57.35	216.8	55.61	210.2	53.87	203.6	5.59	4.2	70.28	52.4	138.38	103.2
	B42 ²⁾	8.39	137.5	65.39	247.2	63.65	240.6	62.15	234.9	6.05	4.5	79.66	59.4	149.39	111.4
	O45 ³⁾	8.89	145.7	69.29	262.0	67.11	253.6	65.47	247.5	6.74	5.0	83.75	62.4	144.41	107.7
O50 ⁴⁾	9.64	157.9	75.14	284.0	72.96	275.8	71.78	271.3	7.08	5.3	90.58	67.5	134.54	100.3	

1) B35-B38 = 280 bar (4060 psi) max.int. 2) B42 = 260 bar (3770 psi) max.int. 3) O45 = 240 bar (3500 psi) max. int. 4) O50 = 210 bar (3000 psi) max. int.
* special 2 1/2 (2.5 dia) suction also available - Please contact VELJAN



VT7E or VT7ES - 072 - 1 R 00 - A 1 M0 -

Series

VT7E series-125 A2 HW
ISO 2 bolts ³ 019-2 mounting flange
VT7ES series- SAE C 2 bolts
Mounting flange J744

Camring

Volumetric displacement cm³/rev (in³/rev)

042 = 1 ³ 2.2 (8.07)	057 = 18 ³ .2 (11.18)
045 = 142.5 (8.70)	062 = 196.6 (12.0)
050 = 158.5 (9.67)	066 = 21 ³ .0 (1 ³ .0)
052 = 16 ³ .8 (10.0)	072 = 227.1 (1 ³ .86)
054 = 170.9 (10.4 ³)	085 = 268.7 (16.40)

Type of shaft VT7E-VT7ES

5 - keyed (ISO R775-G³ 8M)

Type of shaft VT7ES

- 1 - keyed (SAE CC)
- 2 - keyed (no SAE)
- ³ - splined (SAE C)
- 4 - splined (SAE CC)

Direction of rotation (view on shaft end)

- R - clockwise
- L - counter-clockwise

Modifications

Mounting w/connection variables

4 bolts SAE flange (J518)

P = 1-1/2" S = 3"	
	UNC METRIC
VT7E	M0
VT7ES	00 M0

Seal class

- 1 - S1 (for mineral oil)
- 4 - S4 (for fire resistant fluids)
- 5 - S5 (for mineral oil and fire resistant fluids)

Design letter

Porting combination

00 - standard

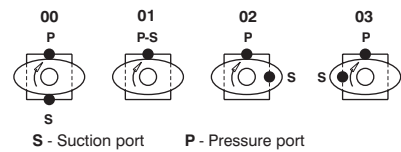

INTERNAL LEAKAGE (TYPICAL)

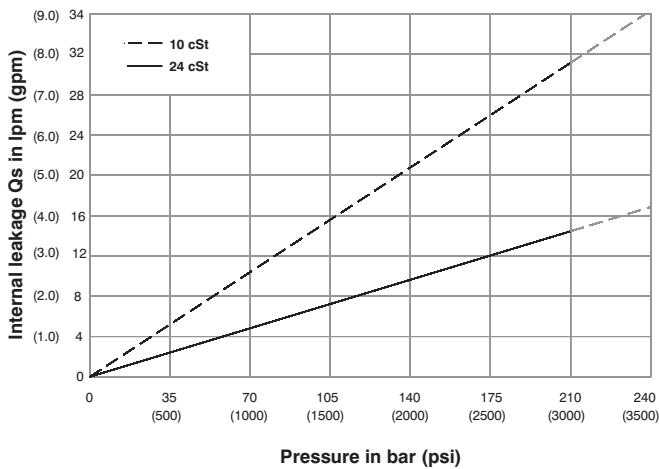

NOISE LEVEL (TYPICAL)

VT7E- 050

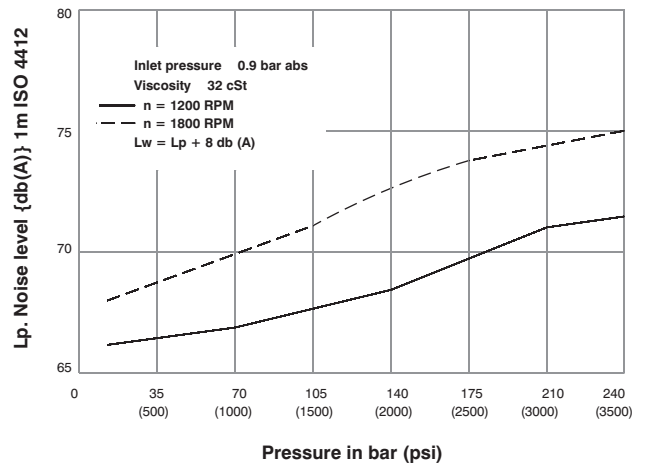

HYDROMECHANICAL POWER LOSS (TYPICAL)

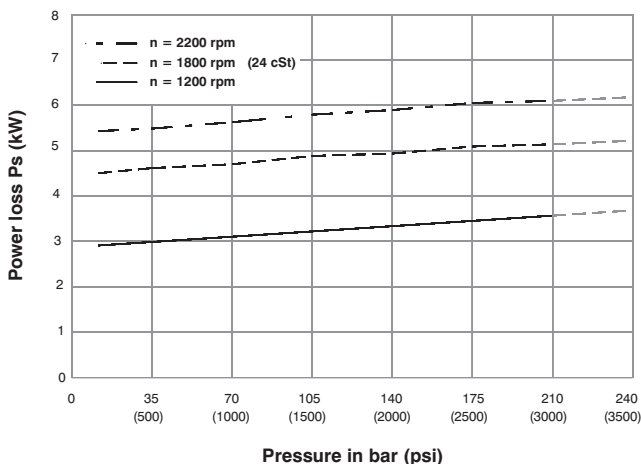

PERMISSIBLE RADIAL LOAD

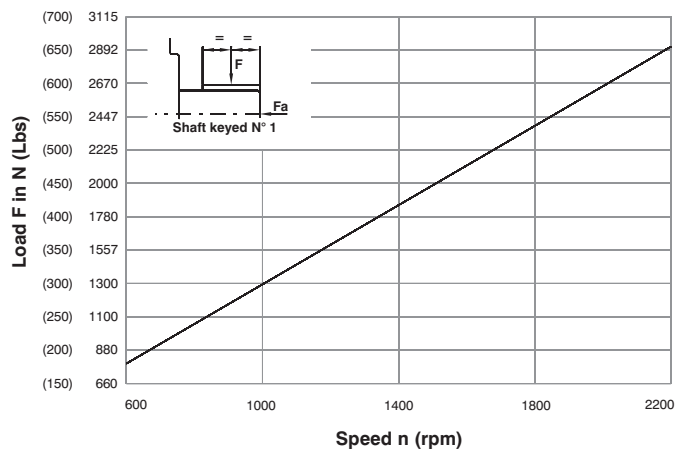

Maximum axial load permissible Fa = 2000 N (449 Lbs)

HIGH PERFORMANCE VANE PUMP VT7E / VT7ES

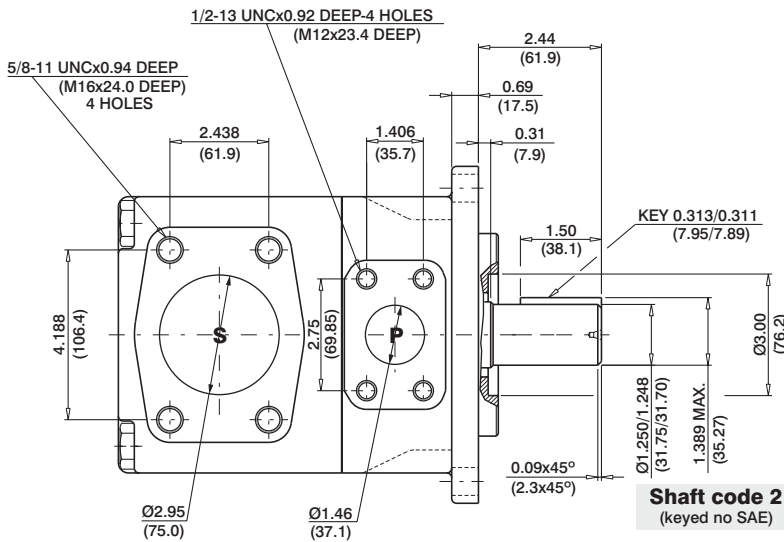

Shaft code 2
(keyed no SAE)

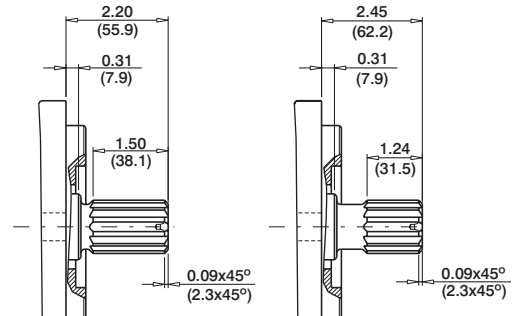

Shaft code 3
SAE C splined shaft
Class 1-J498b
12/24 dp. 14 teeth
30° pressure angle
flat root side fit

Shaft code 4
SAE CC splined shaft
Class 1-J498b
16/32 dp. 17 teeth
30° pressure angle
flat root side fit

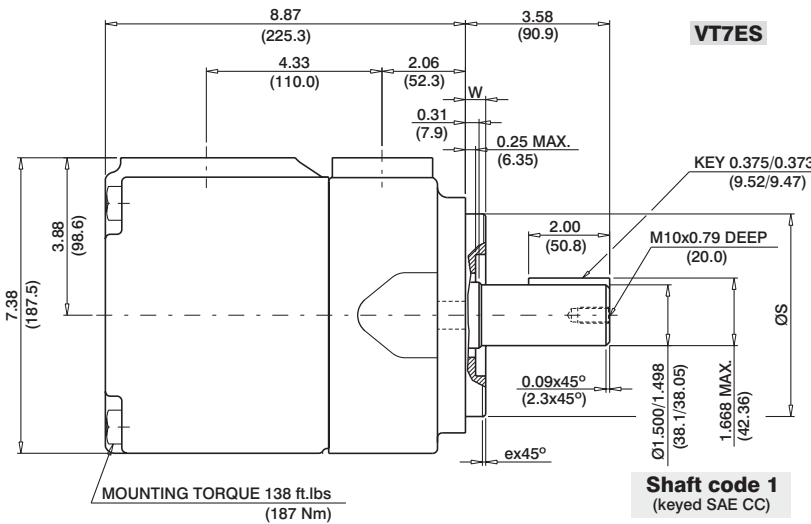

VT7ES

Shaft code 1
(keyed SAE CC)

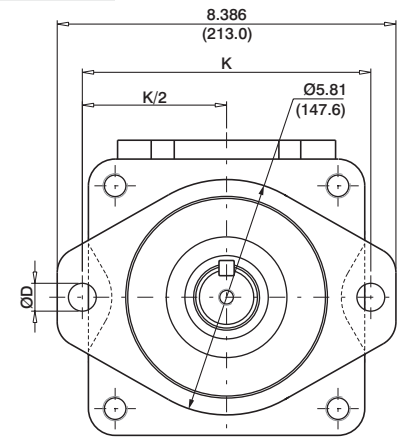

Shaft torque limits in ³ /rev x psi (ml/rev x bar)	
Shaft	Vp x p max.
1	48273 (54555)
2	30638 (34590)
3	54207 (61200)
4	54207 (61200)
5	48273 (54555)

Series	Alternate mounting flange		ex45°	W	K	ØD
	MAX.	Min.				
VT7E	4.921 (124.99)	4.919 (124.94)	0.079 (2.0)	0.374 (9.49)	7.087 (180.0)	0.709 (18.0)
VT7ES	5.00 (127.00)	4.998 (126.94)	0.051 (1.3)	0.50 (12.7)	7.126 (181.0)	0.689 (17.5)

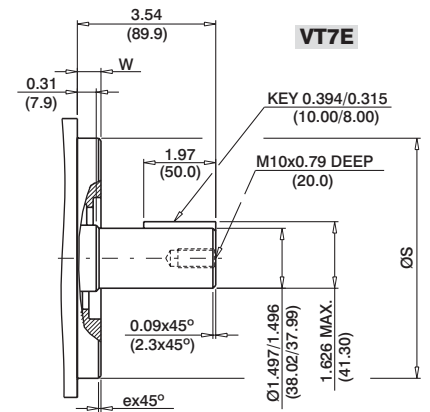

Shaft code 5
(Keyed ISO R775 - G38M)

OPERATING CHARACTERISTICS - TYPICAL (24 cST)

Pressure port	Series	Volumetric Displacement Vp		Flow q & n = 1800 rpm						Input power p & n = 1800 rpm					
		p = 0 bar (0 psi)		p = 140 bar (2000 psi)		p = 240 bar (3500 psi)		p = 7 bar (100 psi)		p = 140 bar (2000 psi)		p = 240 bar (3500 psi)			
		in ³ /rev	cm ³ /rev	gpm	lpm	gpm	lpm	gpm	lpm	hp	kw	hp	kw	hp	kw
VT7E VT7ES	042	8.07	132.2	62.92	237.8	60.37	228.2	58.52	221.2	8.09	6.03	78.44	58.49	133.80	99.77
	045	8.70	142.5	67.72	255.9	65.17	246.3	63.32	239.3	8.37	6.24	84.04	62.66	143.60	107.08
	050	9.67	158.5	75.38	284.9	72.83	275.3	70.98	268.3	8.82	6.58	92.97	69.32	159.24	118.75
	052	10.00	163.8	78.37	296.2	75.82	286.6	73.97	279.6	8.99	6.70	96.47	71.94	165.36	123.31
	054	10.43	170.9	81.27	307.2	78.72	297.6	76.87	290.6	9.17	6.84	99.75	74.38	177.46	132.33
	057	11.18	183.2	87.12	329.3	84.57	319.7	82.72	312.7	9.51	7.09	106.57	79.47	189.84	141.56
	062	12.00	196.6	93.54	353.6	90.99	343.9	89.14	336.9	9.88	7.37	114.17	85.13	196.34	146.41
	066	13.00	213.0	101.44	383.4	98.89	373.8	97.04	366.8	10.34	7.71	123.38	92.0	212.46	158.43
	072	13.86	227.1	108.00	408.2	105.45	398.6	103.60	391.6	10.72	7.99	131.04	97.71	225.86	166.42
	085 ¹⁾	16.40	268.7	127.79	483.0	126.13	476.7	--	--	11.88	8.85	101.66	75.80	--	--

1) 085 = 90 bar (1300 psi) max.int. & 085 = 2000 rpm max.

* special 3 1/2 (3.5 dia) suction also available - Please contact VELJAN