

Description

This type of Inverted Bucket Steam Trap is designed for installation in horizontal pipe work with cast iron body and bolted cover. They are maintainable and offer a wide range of capacities. It is suitable for use where trap inlet pressure can vary, where Δp is sometimes positive or negative.

Limiting Conditions

Body Design Conditions	PN16
PMO - Maximum Operating Pressure	14 kgf/cm ²
TMO - Maximum Operating Temperature	200 °C
PMA - Maximum Allowable Pressure	16 kgf/cm ²
TMA - Maximum Allowable Temperature	220 °C
Cold Hydraulic Test Pressure	24 kgf/cm ²



Operating Range

ΔPMX – Maximum differential pressure 16 kgf/cm²

Sizes and Pipe Connections

½", ¾" and 1" Screwed (ANSI B1.20.1) - Flanged (ANSI B16.5)

Dimensions / Weights (Approximate) mm and kg

Size	A	B	C	Weight
½"	65	115	125	5.5
¾"	65	115	125	5.5
1"	85	135	155	7.5

Constructions are a bit different according the sizes.

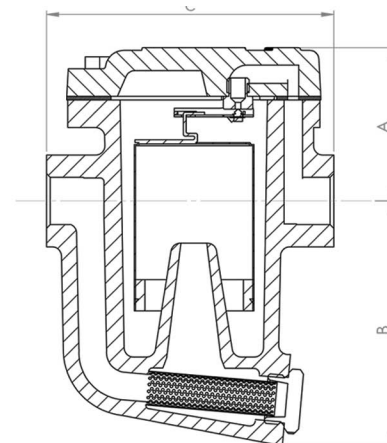

Horizontal Inverted Bucket Steam Traps – 222

Materials

No.	Part	Material
1	Cover	GG 25
2	Gasket *	Clingrit
3	Balance Weight *	Gray Cast
4	Bucket Assembly *	AISI 304
5	Plug *	AISI 304
6	Plug Support *	AISI 304
7	Bolt	AISI 304
8	Seat *	AISI 316
9	Body	GG 25
10	Bolt	C.S.
11	Valve Plug	AISI 316
12	Strainer Screen *	AISI 304/316
13	Strainer Cap	AISI 420

Note: (*) Spare Part

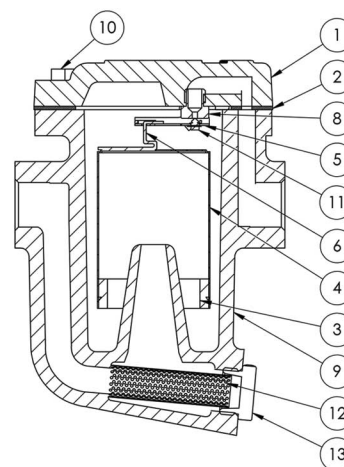

Capacities

Maximum continual discharge amount (kg/h)

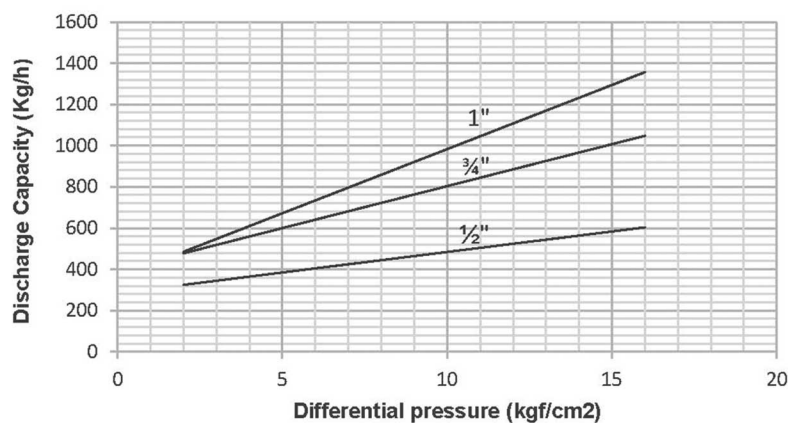

Note: Traps should be selected for the most appropriate working pressure differential and not on the basis of load.

Installation

The trap must be installed with the body upright so that the bucket is rising and falling vertically. The trap should be installed below the drain point so that a water seal can be maintained around the open end of the bucket.

How to Order

Example: IB222 – ½", Horizontal Inverted Bucket Steam Trap.